

APJ ABDUL KALAM  
TECHNOLOGICAL  
UNIVERSITY

# SEMESTER V

KTU



ECT301	LINEAR INTEGRATED CIRCUITS	CATEGORY	L	T	P	CREDITS
		PCC	3	1	0	4

**Preamble:** This course aims to develop the skill to design circuits using operational amplifiers and other linear ICs for various applications.

**Prerequisite:** EC202 Analog Circuits

**Course Outcomes:** After the completion of the course the student will be able to

CO 1	Understand Op Amp fundamentals and differential amplifier configurations
CO 2	Design operational amplifier circuits for various applications
CO 3	Design Oscillators and active filters using opamps
CO4	Explain the working and applications of timer, VCO and PLL ICs
CO5	Outline the working of Voltage regulator IC's and Data converters

**Mapping of course outcomes with program outcomes**

	PO 1	PO 2	PO 3	PO 4	PO 5	PO 6	PO 7	PO 8	PO 9	PO 10	PO 11	PO 12
CO 1	3	3	1	2								1
CO 2	3	3	2	2	2							1
CO 3	3	3	2	2	2							1
CO 4	3	3	1	2	2							1
CO 5	3	3	2	2	2							1

**Assessment Pattern**

Bloom's Category		Continuous Assessment Tests		End Semester Examination
		1	2	
Remember	K1	10	10	10
Understand	K2	30	30	60
Apply	K3	10	10	30
Analyse	K4			
Evaluate				
Create				

**Mark distribution**

Total Marks	CIE	ESE	ESE Duration
150	50	100	3 hours

**Continuous Internal Evaluation Pattern:**

Attendance	: 10 marks
Continuous Assessment Test (2 numbers)	: 25 marks
Assignment/Quiz/Course project	: 15 marks

**End Semester Examination Pattern:** There will be two parts; Part A and Part B. Part A contain 10 questions with 2 questions from each module, having 3 marks for each question. Students should answer all questions. Part B contains 2 questions from each module of which student should answer any one. Each question can have maximum 2 sub-divisions and carry 14 marks.

**Course Level Assessment Questions****Course Outcome 1 (CO1): Analyze differential amplifier configurations.**

1. Explain the working of BJT differential amplifiers.
2. Calculate the input resistance, output resistance, voltage gain and CMRR of differential amplifiers.
3. Explain the non-ideal parameters of differential amplifiers.
4. Derive CMRR, input resistance and output resistance of a dual input balanced output differential amplifier configuration.

**Course Outcome 2 (CO2): Design operational amplifier circuits for various applications.**

1. Design an opamp circuit to obtain an output voltage  $V_0 = -(2V_1 + 4V_2 + 3V_3)$
2. A 741C op-amp is used as an inverting amplifier with a gain of 50. The voltage gain vs frequency curve of 741C is flat upto 20kHz. What maximum peak to peak input signal can be applied without distorting the output?
3. With the help of a neat circuit diagram, derive the equation for the output voltage of an Instrumentation amplifier.
4. With the help of circuit diagrams and graphs, explain the working of a Full wave Precision rectifier.

**Course Outcome 3 (CO3): Design active filters using opamps**

1. Derive the design equations for a second order Butterworth active low pass filter.
2. Design a Notch filter to eliminate power supply hum (50 Hz).
3. Design a first order low pass filter at a cut-off frequency of 2kHz with a pass band gain of 3

**Course Outcome 4 (CO4): Explain the working and applications of specialized ICs**

1. With the help of internal diagram explain the monostable operation of timer IC 555. Draw the input and different output waveforms. Derive the equation for pulse width.
2. Explain the operation of Phase Locked Loop. What is lock range and capture range? Realize a summing amplifier to obtain a given output voltage.

3. Design a circuit to multiply the incoming frequency by a factor of 5 using 565 PLL.

**Course Outcome 5 (CO5): Outline the working of Voltage regulator IC's and Data converters**

1. What is the principle of operation of Dual slope ADC. Deduce the relationship between analogue input and digital output of the ADC.
2. Explain how current boosting is achieved using I.C 723
3. Explain the working of successive approximation ADC

**SYLLABUS**

**Module 1:**

**Operational amplifiers(Op Amps):** The 741 Op Amp, Block diagram, Ideal op-amp parameters, typical parameter values for 741, Equivalent circuit, Open loop configurations, Voltage transfer curve, Frequency response curve.

**Differential Amplifiers:** Differential amplifier configurations using BJT, DC Analysis- transfer characteristics; AC analysis- differential and common mode gains, CMRR, input and output resistance, Voltage gain. Constant current bias, constant current source; – Concept of current mirror-the two transistor current mirror, Wilson and Widlar current mirrors.

**Module 2:**

**Op-amp with negative feedback:** General concept of – Voltage Series, Voltage Shunt, current series and current shunt negative feedback, Op Amp circuits with voltage series and voltage shunt feedback, Virtual ground Concept; analysis of practical inverting and non-inverting amplifiers for closed loop gain, Input Resistance and Output Resistance.

**Op-amp applications:** Summer, Voltage Follower-loading effects, Differential and Instrumentation Amplifiers, Voltage to current and Current to voltage converters, Integrator, Differentiator, Precision rectifiers, Comparators, Schmitt Triggers, Log and antilogamplifiers.

**Module 3:**

**Op-amp Oscillators and Multivibrators:** Phase Shift and Wien-bridge Oscillators, Triangular and Sawtooth waveform generators, Astable and monostable multivibrators.

**Active filters:** Comparison with passive filters, First and second order low pass, High pass, Band pass and band reject active filters, state variable filters.

**Module 4 :**

**Timer and VCO:** Timer IC 555- Functional diagram, Astable and monostable operations;. Basic concepts of Voltage Controlled Oscillator and application of VCO IC LM566,

**Phase Locked Loop –** Operation, Closed loop analysis, Lock and capture range, Basic building blocks, PLL IC 565, Applications of PLL.

**Module 5:**

**Voltage Regulators:** Fixed and Adjustable voltage regulators, IC 723 – Low voltage and high voltage configurations, Current boosting, Current limiting, Short circuit and Fold-back protection.

**Data Converters:** Digital to Analog converters, Specifications, Weighted resistor type and R-2R Ladder type.

Analog to Digital Converters: Specifications, Flash type and Successive approximation type.

**Text Books**

1. Roy D. C. and S. B. Jain, Linear Integrated Circuits, New Age International, 3/e, 2010

**Reference Books**

1. D.Franco S., Design with Operational Amplifiers and Analog Integrated Circuits, 3/e, Tata McGraw Hill, 2008
2. Gayakwad R. A., Op-Amps and Linear Integrated Circuits, Prentice Hall, 4/e, 2010
3. Salivahanan S. and V. S. K. Bhaaskaran, Linear Integrated Circuits, Tata McGraw Hill, 2008.
4. Botkar K. R., Integrated Circuits, 10/e, Khanna Publishers, 2010
5. C.G. Clayton, Operational Amplifiers, Butterworth & Company Publ. Ltd. Elsevier, 1971
6. David A. Bell, Operational Amplifiers & Linear ICs, Oxford University Press, 2<sup>nd</sup> edition, 2010
7. R.F. Coughlin & Fredrick Driscoll, Operational Amplifiers & Linear Integrated Circuits, 6<sup>th</sup> Edition, PHI, 2001
8. Sedra A. S. and K. C. Smith, Microelectronic Circuits, 6/e, Oxford University Press, 2013.

**Course Contents and Lecture Schedule**

No	Topic	No. of Lectures
<b>1</b>	<b>Operational amplifiers</b>	<b>(9)</b>
1.1	The 741 Op Amp, Block diagram, Ideal op-amp parameters, typical parameter values for 741	1
1.2	Equivalent circuit, Open loop configurations, Voltage transfer curve, Frequency response curve.	1
1.3	Differential amplifier configurations using BJT, DC Analysis- transfer characteristics	2
1.4	AC analysis- differential and common mode gains, CMRR, input and output resistance, Voltage gain	2
1.5	Constant current bias and constant current source	1
1.6	Concept of current mirror, the two transistor current mirror Wilson and Widlar current mirrors.	2
<b>2</b>	<b>Op-amp with negative feedback and Op-amp applications</b>	<b>(11)</b>

2.1	General concept of Voltage Series, Voltage Shunt, current series and current shunt negative feedback	1
2.2	Op Amp circuits with voltage series and voltage shunt feedback, Virtual ground Concept	1
2.3	Analysis of practical inverting and non-inverting amplifier	2
2.4	Summer, Voltage Follower-loading effect	1
2.5	Differential and Instrumentation Amplifiers	1
2.6	Voltage to current and Current to voltage converters	1
2.7	Integrator, Differentiator	1
2.8	Precision rectifiers-half wave and full wave	1
2.9	Comparators, Schmitt Triggers	1
2.10	Log and antilog amplifier	1
<b>3</b>	<b>Op-amp Oscillators and Multivibrators</b>	<b>(10)</b>
3.1	Phase Shift and Wien-bridge Oscillators,	2
3.2	Triangular and Sawtooth waveform generators, Astable and monostable multivibrators	2
3.3	Comparison, design of First and second order low pass and High pass active filters	2
3.4	Design of Second Order Band pass and band reject filters	2
3.5	State variable filters	2
<b>4</b>	<b>Timer, VCO and PLL</b>	<b>(9)</b>
4.1	Timer IC 555- Functional diagram, Astable and monostable operations.	2
4.2	Basic concepts of Voltage Controlled Oscillator	1
4.3	Application of VCO IC LM566	2
4.4	PLL Operation, Closed loop analysis Lock and capture range.	2
4.5	Basic building blocks, PLL IC 565, Applications of PLL	2
<b>5</b>	<b>Voltage regulators and Data converters</b>	<b>(9)</b>
5.1	Fixed and Adjustable voltage regulators	1
5.2	IC 723 – Low voltage and high voltage configurations,	2
5.3	Current boosting, Current limiting, Short circuit and Fold-back protection.	2
5.4	Digital to Analog converters, Specifications, Weighted resistor type and R-2R Ladder type.	2
5.5	Analog to Digital Converters: Specifications, Flash type and Successive approximation type.	2

**Assignment:**

Assignment may be given on related innovative topics on linear IC, like Analog multiplier- Gilbert multiplier cell, variable trans-conductance technique, application of analog multiplier IC AD633., sigma delta or other types of ADC etc. At least one assignment should be simulation of opamp circuits on any circuit simulation software. The following simulations can be done in QUCS, KiCad or PSPICE.(The course instructor is free to add or modify the list)

1. Design and simulate a BJT differential amplifier. Observe the input and output signals. Plot the AC frequency response
2. Design and simulate Wien bridge oscillator for a frequency of 10 kHz. Run a transient simulation and observe the output waveform.
3. Design and implement differential amplifier and measure its CMRR. Plot its transfer characteristics.
4. Design and simulate non-inverting amplifier for gain 5. Observe the input and output signals. Run the ac simulation and observe the frequency response and 3- db bandwidth.
5. Design and simulate a 3 bit flash type ADC. Observe the output bit patterns and transfer characteristics
6. Design and simulate R – 2R DAC circuit.
7. Design and implement Schmitt trigger circuit for upper triggering point of +8 V and a lower triggering point of -4 V using op-amps.

**Model Question****APJ ABDUL KALAM TECHNOLOGICAL UNIVERSITY**

FIFTH SEMESTER B.TECH DEGREE EXAMINATION, (Model Question Paper)

Course Code: ECT301

Program: Electronics and Communication Engineering

Course Name: Linear Integrated Circuits

Max. Marks: 100

Duration: 3 Hours

**PART A**

Answer ALL Questions. Each Carries 3 mark.

1. Draw and list the functions of 741 IC pins K1
  2. Define slew rate with its unit. What is its effect at the output signal? K2
  3. How the virtual ground is different from actual ground? K2
  4. A differential amplifier has a common mode gain of 0.05 and difference mode gain of 1000. Calculate the output voltage for two signals  $V_1 = 1\text{mV}$  and  $V_2 = 0.9\text{mV}$  K3
  5. Design a non-inverting amplifier for a gain of 11 K3
  6. Design a second order Butterworth Low Pass Filter with  $f_H = 2\text{KHz}$  K3
  7. Draw the circuit of monostable multivibrator using opamp. K1
  8. What is the principle of VCO?. K1
  9. Mention 3 applications of PLL. K2
  10. Define the following terms with respect to DAC (i)Resolution (ii)Linearity (iii) Full scale output voltage K2
- Differentiate between line and load regulations. K3

**PART – B**

Answer one question from each module; each question carries 14 marks.

<b>Module I</b>				
11. a)	Derive CMRR, input resistance and output resistance of a dual input balanced output differential amplifier configuration.	7	CO1	K3
11. b)	What is the principle of operation of Wilson current mirror and its advantages? Deduce the expression for its current gain.	7	CO1	K2
<b>OR</b>				
12.a)	Draw the equivalent circuit of an operational amplifier. Explain voltage transfer characteristics of an operational amplifier.	6	CO1	K3
12.b)	Explain the following properties of a practical opamp (i) Bandwidth (ii) Slew rate (iii) Input offset voltage (iv) Input offset current	8	CO1	K2
<b>Module II</b>				



13. a)	Design a fullwave rectifier to rectify an ac signal of 0.2V peak-to-peak. Explain its principle of operation.	7	CO2	K3
13. b)	Draw the circuit diagram of a differential instrumentation amplifier with a transducer bridge and show that the output voltage is proportional to the change in resistance.	7	CO2	K2
<b>OR</b>				
14.a)	Derive the following characteristics of voltage shunt amplifier: i) Closed loop voltage gain ii) Input resistance iii) Output resistance iv) Bandwidth	7	CO2	K3
14.b)	Explain the working of an inverting Schmitt trigger and draw its transfer characteristics.	7	CO2	K2
<b>Module III</b>				
15 a)	Derive the equation for frequency of oscillation ( $f_0$ ) of a Wein Bridge oscillator. Design a Wein Bridge oscillator for $f_0 = 1\text{KHz}$ .	7	CO3	K3
15 b)	Derive the equation for the transfer function of a first order wide Band Pass filter.	7	CO3	K3
<b>OR</b>				
16a	Derive the design equations for a second order Butterworth active low pass filter.	7	CO3	K3
16b	Design a circuit to generate 1KHz triangular wave with 5V peak.	7	CO3	K3
<b>Module IV</b>				
17 a)	Design a circuit to multiply the incoming frequency by a factor of 5 using 565 PLL.	8	CO4	K3
17 b)	With the help of internal diagram explain the monostable operation of timer IC 555. Draw the input and output waveforms. Derive the equation for pulse width.	6	CO4	K2
<b>OR</b>				
18 a)	Design a monostable multi-vibrator for a pulse duration of 1ms using IC555.	7	CO4	K3
18 b)	Explain the operation of Phase Locked Loop. What is lock range and capture range?	7	CO4	K2
<b>Module V</b>				
19 a)	Explain the working of R-2R ladder type DAC. In a 10 bit DAC, reference voltage is given as 15V. Find analog output for digital input of 1011011001.	7	CO5	K2
19 b)	Explain how short circuit, fold back protection and current boosting are done using IC723 voltage regulator.	7	CO5	K2
<b>OR</b>				
20 a)	With a functional diagram, explain the principle of operation of Successive approximation type ADC.	7	CO5	K2
20 b)	With a neat circuit diagram, explain the operation of a 3-bit flash converter.	7	CO5	K2

ECT303	DIGITAL SIGNAL PROCESSING	CATEGORY	L	T	P	CREDIT
		PCC	3	1	0	4

**Preamble:** This course aims to provide an understanding of the principles, algorithms and applications of DSP.

**Prerequisite:** ECT 204 Signals and systems

**Course Outcomes:** After the completion of the course the student will be able to

CO 1	State and prove the fundamental properties and relations relevant to DFT and solve basic problems involving DFT based filtering methods
CO 2	Compute DFT and IDFT using DIT and DIF radix-2 FFT algorithms
CO 3	Design linear phase FIR filters and IIR filters for a given specification
CO 4	Illustrate the various FIR and IIR filter structures for the realization of the given system function
CO5	Explain the basic multi-rate DSP operations decimation and interpolation in both time and frequency domains using supported mathematical equations
CO6	Explain the architecture of DSP processor (TMS320C67xx) and the finite word length effects

**Mapping of course outcomes with program outcomes**

	PO 1	PO 2	PO 3	PO 4	PO 5	PO 6	PO 7	PO 8	PO 9	PO 10	PO 11	PO 12
CO 1	3	3	2		2							2
CO 2	3	3	3		3							2
CO 3	3	3	3		3							2
CO 4	3	3	2		3							2
CO5	2	2	2		2							2
CO6	2	2	-		-							2

**Assessment Pattern**

Bloom's Category		Continuous Assessment Tests		End Semester Examination
		1	2	
Remember	K1	10	10	10
Understand	K2	20	20	30
Apply	K3	20	20	60
Analyse	K4			
Evaluate				
Create				

**Mark distribution**

Total Marks	CIE	ESE	ESE Duration
150	50	100	3 hours

**Continuous Internal Evaluation Pattern:**

Attendance	: 10 marks
Continuous Assessment Test (2 numbers)	: 25 marks
Assignment/Quiz/Course project	: 15 marks

**End Semester Examination Pattern:** There will be two parts; Part A and Part B. Part A contain 10 questions with 2 questions from each module, having 3 marks for each question. Students should answer all questions. Part B contains 2 questions from each module of which student should answer any one. Each question can have maximum 2 sub-divisions and carry 14 marks.

**Course Level Assessment Questions****CO1: State and prove the fundamental properties and relations relevant to DFT and solve basic problems involving DFT based filtering methods**

- Determine the N-point DFT  $X(k)$  of the N point sequences given by (i)  $x_1(n) = \sin(2\pi n/N)$   $n/N$   
(ii)  $x_2(n) = \cos^2(2\pi n/N)$   $n/N$
- Show that if  $x(n)$  is a real valued sequence, then its DFT  $X(k)$  is also real and even

**CO2: Compute DFT and IDFT using DIT and DIF radix-2 FFT algorithms**

- Find the 8 point DFT of a real sequence  $x(n) = \{1, 2, 2, 2, 1, 0, 0, 0\}$  using Decimation in frequency algorithm?
- Find out the number of complex multiplications require to perform an 1024 point DFT using (i) direct computation and (ii) using radix 2 FFT algorithm?

**CO3: Design linear phase FIR filters and IIR filters for a given specification**

- Design a linear phase FIR filter with order  $M=15$  and cut-off frequency  $\pi n/N) /6$  .Use a Hanning Window.
- Design a low pass digital butter-worth filter using bilinear transformation for the given specifications. Passband ripple  $\leq 1$ dB, Passband edge:4kHz, Stopband Attenuation: $\geq 40$  dB, Stopband edge:6kHz, Sampling requency:24 kHz

**CO4: Illustrate the various FIR and IIR filter structures for the realization of the given system function**

1. Obtain the direct form II and transpose structure of the filter whose transfer function is given below.

$$H(z) = \frac{0.44z^2 + 0.362z + 0.02}{z^3 + 0.4z^2 + 0.18z - 0.2}$$

2. Realize an FIR system with the given difference equation  $y(n) = x(n) - 0.5x(n-1) + 0.25x(n-2) + 0.5x(n-3) - 0.4x(n-4) + 0.2x(n-5)$

**CO5: Explain the basic multi-rate DSP operations decimation and interpolation in both time and frequency domains using supported mathematical equations**

1. Derive the frequency domain expression of the factor of 2 up-sampler whose input is given by  $x(n)$  and transform by  $X(k)$ ?
2. Bring out the role of an anti-imaging filter in a sampling rate converter?

**CO6: Explain the architecture of DSP processor TMS320C67xx and the finite word length effects**

1. Derive the variance of quantization noise in an ADC with step size  $\Delta$ , assuming uniformly distributed quantization noise with zero mean ?
2. Bring out the architectural features of TMS320C67xx digital signal processor?

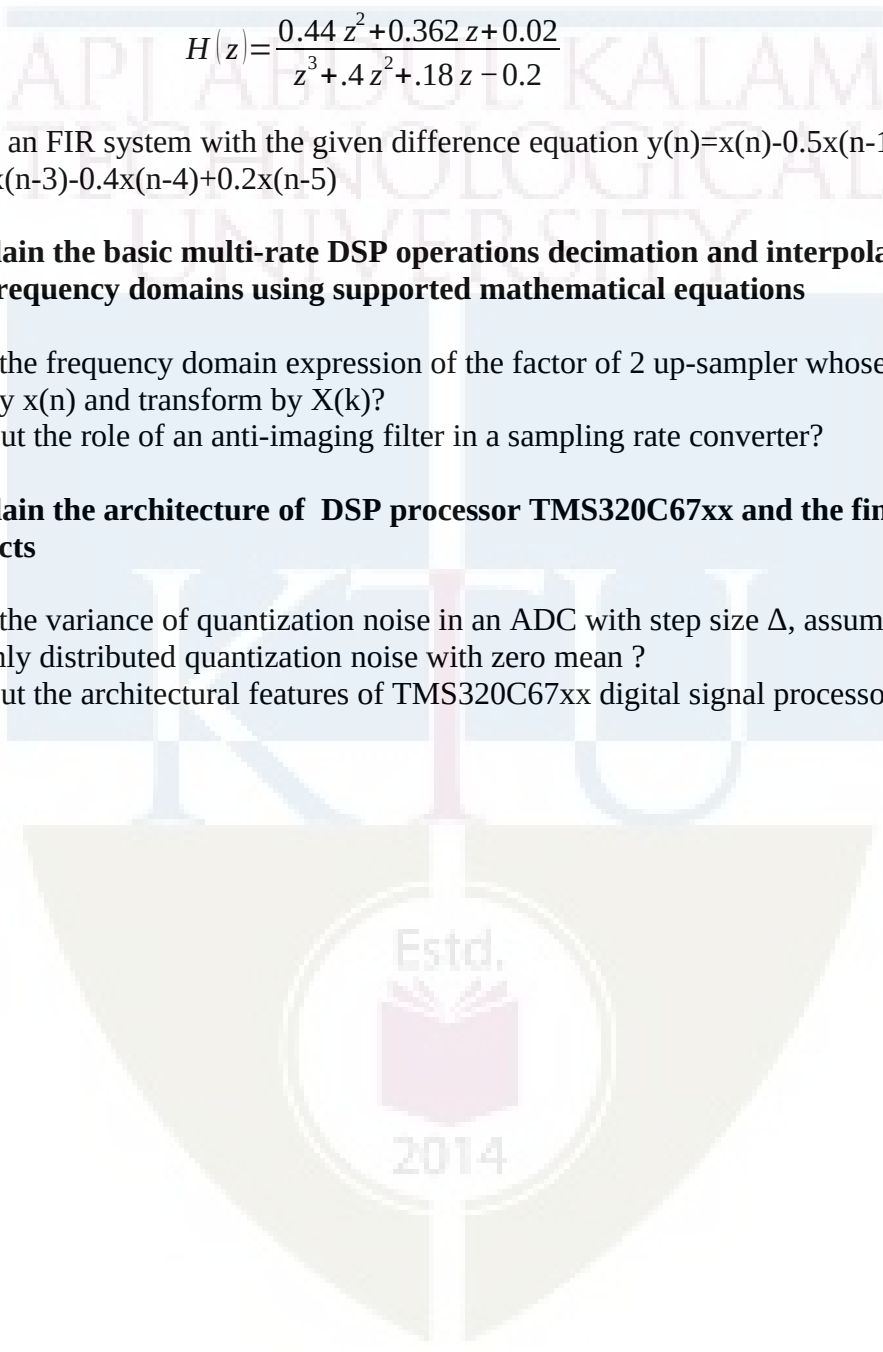

**SYLLABUS****Module 1**

Basic Elements of a DSP system, Typical DSP applications, Finite-length discrete transforms, Orthogonal transforms – The Discrete Fourier Transform: DFT as a linear transformation (Matrix relations), Relationship of the DFT to other transforms, IDFT, Properties of DFT and examples. Circular convolution, Linear Filtering methods based on the DFT, linear convolution using circular convolution, Filtering of long data sequences, overlap save and overlap add methods, Frequency Analysis of Signals using the DFT (concept only required)

**Module 2**

Efficient Computation of DFT: Fast Fourier Transform Algorithms-Radix-2 Decimation in Time and Decimation in Frequency FFT Algorithms, IDFT computation using Radix-2 FFT Algorithms, Application of FFT Algorithms, Efficient computation of DFT of Two Real Sequences and a  $2N$ -Point Real Sequence

**Module 3**

Design of FIR Filters - Symmetric and Anti-symmetric FIR Filters, Design of linear phase FIR filters using Window methods, (rectangular, Hamming and Hanning) and frequency sampling method, Comparison of design methods for Linear Phase FIR Filters. Design of IIR Digital Filters from Analog Filters (Butterworth), IIR Filter Design by Impulse Invariance, and Bilinear Transformation, Frequency Transformations in the Analog and Digital Domain.

**Module 4**

Structures for the realization of Discrete Time Systems - Block diagram and signal flow graph representations of filters, FIR Filter Structures: Linear structures, Direct Form, Cascade Form, IIR Filter Structures: Direct Form, Transposed Form, Cascade Form and Parallel Form, Computational Complexity of Digital filter structures. Multi-rate Digital Signal Processing: Decimation and Interpolation (Time domain and Frequency Domain Interpretation), Anti-aliasing and anti-imaging filter.

**Module 5**

Computer architecture for signal processing: Harvard Architecture, pipelining, MAC, Introduction to TMS320C67xx digital signal processor, Functional Block Diagram. Finite word length effects in DSP systems: Introduction (analysis not required), fixed-point and floating-point DSP arithmetic, ADC quantization noise, Finite word length effects in IIR digital filters: coefficient quantization errors. Finite word length effects in FFT algorithms: Round off errors

**Text Books**

1. Proakis J. G. and Manolakis D. G., Digital Signal Processing, 4/e, Pearson Education, 2007
2. Alan V Oppenheim, Ronald W. Schaffer, Discrete-Time Signal Processing, 3rd Edition, Pearson, 2010

3. Mitra S. K., Digital Signal Processing: A Computer Based Approach, 4/e McGraw Hill (India) 2014

### Reference Books

4. Ifeachor E.C. and Jervis B. W., Digital Signal Processing: A Practical Approach, 2/e Pearson Education, 2009.
5. Lyons, Richard G., Understanding Digital Signal Processing, 3/e. Pearson Education India, 2004.
6. Salivahanan S, Digital Signal Processing, 4e, Mc Graw –Hill Education New Delhi, 2019
7. Chassaing, Rulph., DSP applications using C and the TMS320C6x DSK. Vol. 13. John Wiley & Sons, 2003.
8. Vinay.K.Ingle, John.G.Proakis, Digital Signal Processing: Bookware Companion Series, Thomson, 2004
9. Chen, C.T., “Digital Signal Processing: Spectral Computation & Filter Design”, Oxford Univ. Press, 2001.
10. Monson H Hayes, “Schaums outline: Digital Signal Processing”, McGraw Hill Professional, 1999

### Course Contents and Lecture Schedule

No.	Topic	No. of Lectures
<b>1</b>	<b>Module 1</b>	
1.1	Basic Elements of a DSP system, Typical DSP applications, Finite length Discrete transforms, Orthogonal transforms	1
1.2	The Discrete Fourier Transform: DFT as a linear transformation(Matrix relations),	1
1.3	Relationship of the DFT to other transforms, IDFT	1
1.4	Properties of DFT and examples ,Circular convolution	2
1.5	Linear Filtering methods based on the DFT- linear convolution using circular convolution, Filtering of long data sequences, overlap save and overlap add methods,	3
1.6	Frequency Analysis of Signals using the DFT(concept only required)	1
<b>2</b>	<b>Module 2</b>	
2.1	Efficient Computation of DFT: Fast Fourier Transform Algorithms	1
2.2	Radix-2 Decimation in Time and Decimation in Frequency FFT Algorithms	4
2.3	IDFT computation using Radix-2 FFT Algorithms	2
2.4	Application of FFT Algorithms-Efficient computation of DFT of Two Real Sequences and a 2N-Point Real Sequence	1
<b>3</b>	<b>Module 3</b>	

3.1	Design of FIR Filters- Symmetric and Anti-symmetric FIR Filters, Design of linear phase FIR filters using Window methods, (rectangular, Hamming and Hanning)	4
3.2	Design of linear phase FIR filters using frequency sampling Method, Comparison of Design Methods for Linear Phase FIR Filters	2
3.3	Design of IIR Digital Filters from Analog Filters, (Butterworth), IIR Filter Design by Impulse Invariance	3
3.4	IIR Filter Design by Bilinear Transformation	2
3.5	Frequency Transformations in the Analog and Digital Domain.	1
4	<b>Module 4</b>	
4.1	Structures for the realization of Discrete Time Systems- Block diagram and signal flow graph representations of filters	2
4.2	FIR Filter Structures: (Linear structures), Direct Form Cascade Form	,2
4.3	IIR Filter Structures: Direct Form, Cascade Form and Parallel Form	3
4.3	Computational Complexity of Digital filter structures.	1
4.4	Multi-rate Digital Signal Processing: Decimation and Interpolation (Time domain and Frequency Domain Interpretation ), Anti-aliasing and anti-imaging filter.	3
5	<b>Module 5</b>	
5.1	Computer architecture for signal processing : Harvard Architecture, pipelining, MAC, Introduction to TMS320C67xx digital signal processor ,Functional Block Diagram	3
5.2	Finite word length effects in DSP systems: Introduction (analysis not required), fixed-point and floating-point DSP arithmetic, ADC quantization noise,	3
5.3	Finite word length effects in IIR digital filters: coefficient quantization errors.	2
5.4	Finite word length effects in FFT algorithms: Round off errors	1



The following simulations to be done in Scilab/ Matlab/ LabView/GNU Octave:

1. Consider a signal given by  $x(n)=[1,1,1,1]$ .
  1. Compute the DTFT of the given sequence and plot its magnitude and phase
  2. Compute the 4 point DFT of the above signal and plot its magnitude and phase
  3. Compare the above plots and obtain the relationship?
2. Zero pad the sequence  $x(n)$  by 4 and compute the 8 point DFT and find the corresponding magnitude and phase plots. Compare the spectra with that in (b) and comment on it.
3. The first five values of the 8 point DFT of a real valued sequence  $x(n)$  are given by  $\{0.25, 0.125-j0.3, 0, 0.125-j0.06, 0.5\}$ . Determine the DFT of each of the following sequences using properties. Hint :IDFT may not be computed.
  1.  $x_1(n)=x((2-n))_8$
  2.  $x_3(n)=x^2(n)$
  3.  $x_4(n)=x(n)e^{j\pi n/N}$  in/4
4. a) Develop a function to implement the over-lap add method using circular convolution operation. The format should be function  $[y]=\text{overlappadd}(x,h,N)$ , where  $y$  is the output sequence,  $x$  is the input sequence and  $N$  is the block - length  $\geq 2*\text{Length}(h)-1$ .
  1. Incorporate the radix-2 FFT implementation in the above function to obtain a high speed overlap add block convolution routine. Choose  $N=8$ . Hint :choose  $N=2^k$
5. Design a low pass digital filter to be used in the given structure

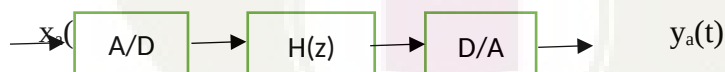

to satisfy the following requirements. Sampling rate of 8000samples/second, Pass band edge of 1500Hz with a ripple of 3dB, Stopband edge of 2000Hz with attenuation of 40 dB, Equiripple passband but monotonic stopband. (Use impulse invariance technique)

1. Choose  $T=1$  s for impulse invariance and determine the system function  $H(z)$  in parallel form. Plot the log-magnitude response in dB and impulse response  $h(n)$
2. Choose  $T=1/8000$  s and repeat the same procedure. Compare this design with that in (a) and comment on the effect of  $T$  on the impulse invariant design?



6. A filter is described by the following difference equation:

$$16y(n)+12y(n-1)+2y(n-2)-4y(n-3)-y(n-4)=x(n)-3x(n-1)+11x(n-2)-27x(n-3)+18x(n-4)$$

1. Determine the Direct form filter structure
  2. Using the Direct form structure, obtain the cascade form filter structure
7. Consider a signal given by  $x(n)=(0.5)^n u(n)$ . Decimate the signal by a factor 4 and plot the output in time domain and frequency domain?
1. Interpolate the signal by a factor of 4 and plot the output in time domain and frequency domain?
  2. Compare the spectra and obtain the inference?

### Model Question Paper

**A P J Abdul Kalam Technological University**

**Fifth Semester B Tech Degree Examination  
Branch: Electronics and Communication Engg.**

**Course: ECT 303 DIGITAL SIGNAL PROCESSING**

Time: 3 Hrs

Max. Marks: 100

#### PART A

**Answer All Questions. Each question carry 3 marks**

1. Derive the relationship of DFT to Z-transform? (3)K3
2. Find the circular convolution of two sequences  $x_1(n)=\{1, 2, -2, 1, 3\}$ ,  $x_2(n)=\{2, -1, 3, 1, 1\}$  (3)K3
3. Illustrate the basic butterfly computation used in decimation in time radix-2 FFT algorithm? (3)K1
4. Bring out the computational advantage of performing an N-point DFT using radix-2 FFT compared to direct method?
5. Determine the frequency response of a linear phase FIR filter given by the difference equation  $y(n)=0.15x(n)+0.25x(n-1)+x(n-3)$ . Also find the phase delay (3) K3
6. An all pole analog filter is given by the transfer function  $H(s)=1/(s^2+5s+6)$ . Find out the transfer function  $H(z)$  of the equivalent digital filter using impulse invariance method. Use  $T=1s$  (3) K3
7. Obtain the cascade form realization of the third order IIR filter transfer function given by
 
$$H(z)=\frac{0.44z^2+0.362z+0.02}{(z^2+0.8z+0.5)(z-0.4)}$$
 (3) K3
8. Prove that a factor of L upsampler is a linear-time varying system. (3) K3
9. Differentiate between Harvard architecture and Von-Nuemann Architecture used in processors? (3) K1
10. Express the fraction  $7/8$  and  $-7/8$  in sign-magnitude, two's complement and one's complement format? (3) K3

**Answer any one Question from each module. Each question carries 14 Marks**

11. a) How will you perform linear convolution using circular convolution? Find the linear convolution of the given sequences  $x(n) = \{2, 9, 7, 4\}$  and  $h(n) = \{1, 3, 1, 2\}$  using circular convolution? (8) K3
- b) Explain the following properties of DFT a) Linearity b) Complex conjugate property c) Circular Convolution d) Time Reversal (6) K2

OR

- 12.a.) The first eight points of 14-point DFT of a real valued sequence are  $\{12, -1+j3, 3+j4, 1-j5, -2+j2, 6+j3, -2-j3, 10\}$
- i) Determine the remaining points
- ii) Evaluate  $x[0]$  without computing the IDFT of  $X(k)$ ?
- iii) Evaluate IDFT to obtain the real sequence ? (8)K3
- b) Explain with appropriate diagrams, the overlap-add method for filtering of long data sequences using DFT? (6) K2
- 13.a) Compute the 8 point DFT of  $x(n) = \{2, 1, -1, 3, 5, 2, 4, 1\}$  using radix-2 decimation in time FFT algorithm. (9) K3
- b) Bring out how a  $2N$  point DFT of a  $2N$  point sequence can be found using the computation of a single  $N$  point DFT. (5) K3

OR

- 14 a.) Find the 8 point DFT of a real sequence  $x(n) = \{1, 2, 2, 2, 1, 0, 0, 0\}$  using radix-2 decimation in frequency algorithm (9)K3
- b) Bring out how  $N$ -point DFT of two real valued sequences can be found by computing a single  $N$ -point DFT. (5) K3
- 15.a. Design a linear phase FIR low pass filter having length  $M = 15$  and cut-off frequency  $\omega_c = \pi/6$ . Use Hamming window. (10) K3
- b. Prove that if  $z_1$  is a zero of an FIR filter, then  $1/z_1$  is also a zero? (4) K2

OR

16. a. Design a digital Butterworth low pass filter with  $\omega_p = \pi/6$ ,  $\omega_s = \pi/4$ , minimum pass band gain = -2 dB and minimum stop band attenuation = 8 dB. Use bilinear transformation. (Take  $T = 1$ s) (10) K3
- b. What is warping effect in bilinear transformation and how it can be eliminated? (4) K2

17.a) Derive and draw the direct form-I, direct form-II and cascade form realization of the given filter, whose difference equation is given as (9) K3

$$y(n) = 0.1y(n-1) + 0.2y(n-2) + 3x(n) + 3.6x(n-1) + 0.6x(n-2)$$

b) Differentiate between anti-aliasing and anti-imaging filters. (5) K2

OR

18.a) Obtain the expression of output  $y(n)$  as a function of  $x(n)$  for the multi-rate structure given below? (9) K3

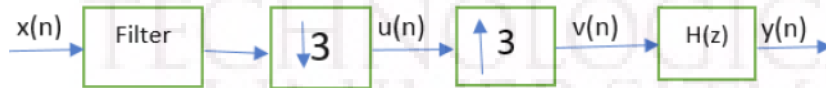

b) Draw the transposed direct form II Structure of the system given by the difference equation  $y(n) = 0.5y(n-1) - 0.25y(n-2) + x(n) + x(n-1)$ . (5) K2

19.a) With the help of a functional block diagram, explain the architecture of TMS320C67xx DSP processor? (10) K2

b) What are the prominent features of TMS320C67xx compared to its predecessors? (4) K2

OR

20.a) Explain how to minimize the effect of finite word length in IIR digital filters? (7) K2

b) Explain the roundoff error models used in FFT algorithms? (7) K2

ECT305	ANALOG AND DIGITAL COMMUNICATION	CATEGORY	L	T	P	CREDIT
		PCC	3	1	0	4

**Preamble:** This course aims to develop analog and digital communication systems.

**Prerequisite:** ECT 204 Signals and Systems, MAT 204 Probability, Random Process and Numerical Methods

**Course Outcomes:** After the completion of the course the student will be able to

CO 1	Explain the existent analog communication systems.
CO 2	Apply the concepts of random processes to LTI systems.
CO 3	Apply waveform coding techniques in digital transmission.
CO 4	Apply GS procedure to develop digital receivers.
CO 5	Apply equalizer design to counteract ISI.
CO 6	Apply digital modulation techniques in signal transmission.

#### Mapping of course outcomes with program outcomes

	PO1	PO2	PO3	PO4	PO5	PO6	PO7	PO8	PO9	PO10	PO11	PO12
CO 1	3	3										
CO 2	3	3	2	3	3							
CO 3	3	3	2	3	3	2						2
CO 4	3	3	2	3	3	2						2
CO 5	3	3	2	3	3	2						2
CO 6	3	3	2	3	3	2						2

#### Assessment Pattern

Bloom's Category	Continuous Assessment Tests		End Semester Examination
	1	2	
Remember	10	10	20
Understand	30	30	60
Apply	10	10	20
Analyse			
Evaluate			
Create			

**Mark distribution**

Total Marks	CIE	ESE	ESE Duration
150	50	100	3 hours

**Continuous Internal Evaluation Pattern:**

Attendance : 10 marks  
 Continuous Assessment Test (2 numbers) : 25 marks  
 Assignment/Quiz/Course project : 15 marks

**End Semester Examination Pattern:** There will be two parts; Part A and Part B. Part A contain 10 questions with 2 questions from each module, having 3 marks for each question. Students should answer all questions. Part B contains 2 questions from each module of which student should answer any one. Each question can have maximum 2 sub-divisions and carry 14 marks.

**Course Level Assessment Questions****Course Outcome 1 (CO1): The existent analog communication system**

1. What are the needs for analog modulation
2. Give the mathematical model of FM signal and explain its spectrum.

**Course Outcome 2 (CO2): Application of random processes**

1. Compute the entropy of a Gaussian random variable.
2. A six faced die is thrown by a player. He gets Rs. 100 if face 6 turns up, loses Rs. 20 if face 3 or 4 turn up, gets Rs. 50 if face 5 turns up and loses Rs 10 if face 1 or 2 turn up. Draw the pdf and CDF for the random variable. Check if it is profitable based on statistical expectation.

**Course Outcome 3 (CO3): Waveform coding**

1. Compute the A and mu law quantized values of a signal that is normalized to 0.8 with  $A=32$  and  $\mu=255$ .
2. Design a 3-tap linear predictor for speech signals with the autocorrelation vector  $[0.95, 0.85, 0.7, 0.6]$ , based on Wiener-Hopf equation. Compute the minimum mean square error.

**Course Outcome 4 (CO4): G-S Procedure and effects in the channel**

1. Apply G-S procedure on the following signals and plot their signal space.

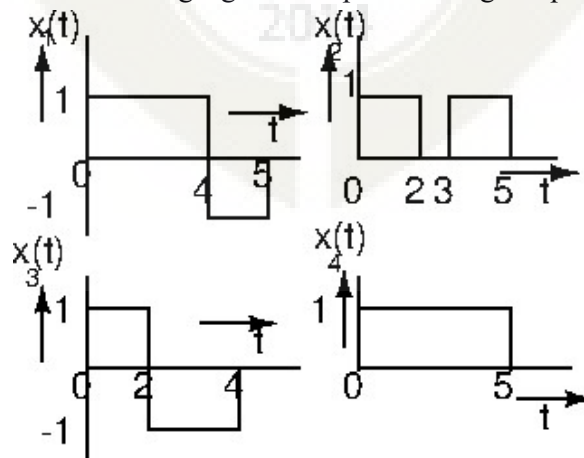

2. Derive the Nyquist criterion for zero ISI.

### **Course Outcome 5 (CO5): Digital modulation**

1. Give the mathematical model of a BPSK signal and plot its signal constellation.
2. Draw the BER-SNR plot for the BPSK system

## **SYLLABUS**

### **Module 1 Analog Communication**

Block diagram of a communication system. Need for analog modulation. Amplitude modulation. Equation and spectrum of AM signal. DSB-SC and SSB systems. Block diagram of SSB transmitter and receiver. Frequency and phase modulation. Narrow and wide band FM and their spectra. FM transmitter and receiver.

### **Module 2 Review of Random Variables and Random Processes**

Review of random variables – both discrete and continuous. CDF and PDF, statistical averages. (Only definitions, computations and significance) Entropy, differential entropy. Differential entropy of a Gaussian RV. Conditional entropy, mutual information. Stochastic processes, Stationarity. Conditions for WSS and SSS. Autocorrelation and power spectral density. LTI systems with WSS as input.

### **Module 3 Source Coding**

Source coding theorems I and II (Statements only). Waveform coding. Sampling and Quantization. Pulse code modulation, Transmitter and receiver. Companding. Practical 15 level A and mu-law companders. DPCM transmitter and receiver. Design of linear predictor. Wiener-Hopf equation. Delta modulation. Slope overload.

### **Module 4 G-S Procedure and Effects in the Channel**

Gram-Schmitt procedure. Signal space. Baseband transmission through AWGN channel. Mathematical model of ISI. Nyquist criterion for zero ISI. Signal modeling for ISI, Raised cosine and Square-root raised cosine spectrum, Partial response signalling and duobinary coding. Equalization. Design of zero forcing equalizer. Vector model of AWGN channel. Matched filter and correlation receivers. MAP receiver, Maximum likelihood receiver and probability of error. Capacity of an AWGN channel (Expression only) -- significance in the design of communication schemes.

### **Module 5 Digital Modulation Schemes**

Digital modulation schemes. Baseband BPSK system and the signal constellation. BPSK

transmitter and receiver. Base band QPSK system and Signal constellations. Plots of BER Vs SNR with analysis. QPSK transmitter and receiver. Quadrature amplitude modulation and signal constellation.

### Text Books

1. "Communication Systems", Simon Haykin, Wiley.
2. "Digital Communications: Fundamentals and Applications", Sklar, Pearson.
3. "Digital Telephony", John C. Bellamy, Wiley

### References

1. "Principles of Digital Communication," R. Gallager, Oxford University Press
2. "Digital Communication", John G Proakis, Wiley.

### Course Contents and Lecture Schedule

No	Topic	No. of Lectures
<b>1</b>	<b>Analog Communication</b>	
1.1	Block diagram of communication system, analog and digital systems , need for modulation	2
1.2	Amplitude modulation, model and spectrum and index of modulation	2
1.3	DSB-SC and SSB modulation. SSB transmitter and receiver	2
1.4	Frequency and phase modulation. Model of FM, spectrum of FM signal	2
<b>2</b>	<b>Review of Random Variables</b>	
2.1	Review of random variables, CDF and PDF, examples	2
2.2	Entropy of RV, Differential entropy of Gaussian RV, Expectation, conditional expectation, mutual information	4
2.3	Stochastic processes, Stationarity, WSS and SSS. Autocorrelation and power spectral density. Response of LTI systems to WSS	3
<b>3</b>	<b>Source Coding</b>	
3.1	Source coding theorems I and II	1
3.2	PCM, Transmitter and receiver, companding Practical A and mu law companders	4
3.3	DPCM, Linear predictor, Wiener Hopf equation	3
3.4	Delta modulator	1

<b>4</b>	<b>GS Procedure and Channel Effects</b>	
4.1	G-S procedure	3
4.2	ISI, Nyquist criterion, RS and SRC, PR signalling and duobinary coding	3
4.3	Equalization, design of zero forcing equalizer	3
4.4	Vector model of AWGN channel, Correlation receiver, matched filter	4
4.5	MAP receiver, ML receiver, probability of error	1
4.6	Channel capacity, capacity of Gaussian channel, Its significance in design of digital communication schemes	2
<b>5</b>	<b>Digital Modulation</b>	
5.1	Need of digital modulation in modern communication.	1
5.2	Baseband QPSK system, signal constellation. Effect of AWGN, probability of error (with derivation). BER-SNR curve, QPSK transmitter and receiver.	4
5.3	QAM system	1





**Model Question Paper****A P J Abdul Kalam Technological University**

Fifth Semester B Tech Degree Examination Branch:

Electronics and Communication

**COURSE: ECT 305 ANALOG AND DIGITAL COMMUNICATION****Time: 3 Hrs****Max. Marks: 100****PART A***Answer All Questions*

- 1 Explain the need for modulation (3)K2
- 2 Plot the spectrum of an FM signal (3)K2
- 3 In a game a six faced die is thrown. If 1 or 2 comes the player gets Rs 30, if 3 or 4 the player gets Rs 10, if 5 comes he loses Rs. 30 and in the event of 6 he loses Rs. 100. Plot the CDF and PDF of gain or loss (3)K3
- 4 Give the conditions for WSS (3)K2
- 5 Compute the step size for a delta modulator without slope overload if the input is  $A \cos 2\pi 120t$  (3)K3
- 6 State source coding theorems I and II (3)K1
- 7 Give the Nyquist criterion for zero ISI. (3)K1
- 8 Give the mathematical model of ISI (3)K2
- 9 Plot BER against SNR for a BPSK system (3)K2
- 10 Draw the signal constellation of a QPSK system with and without AWGN. (3)K3

**PART B**

*Answer one question from each module. Each question carries 14 mark.*

**Module I**

- 11(A) Give the model of AM signal and plot its spectrum (10)K2  
 11(B) If a sinusoidal is amplitude modulated by the carrier (4)K3  
 $5 \cos 2\pi 300t$  to a depth of 30 %, compute the power in the resultant AM signal.

**OR**

- 12(A) Explain how SSB is transmitted and received. (10)K2  
 12(B) Compute the bandwidth of the narrow band FM signal with (4)K3  
 modulating signal frequency of 1kHz and index of modulation 0.3

**Module II**

- 13(A) Compute the entropy of Gaussian random variable. (10)K3  
 13(B) Give the relation between autocorrelation and power (4)K2  
 spectral density of a WSS.

**OR**

- 14(A) Test whether the random process  $X(t) = A \cos 2\pi ft + \theta$  is (10)K3  
 WSS if  $\theta$  is uniformly distributed in the interval  $[-\pi, \pi]$   
 14(B) Explain mutual information. Give its relation with self in- (4)K2  
 formation.

**Module III**

- 15(A) A WSS process with autocorrelation  $R_X(\tau) = e^{-\alpha|\tau|}$  is (10)K3  
 applied to an LTI system with impulse response  $h(t) = e^{-\beta t}$  with  $|\alpha| > 0$  and  $|\beta| > 0$ . Find the output power spectral density  
 15(B) Give the conditions for stationarity in the strict sense. (4)K2

**OR**

- 16(A) Find an orthonormal basis set for the set of signals (7)K3

$$s_1(t) = A \sin(2\pi f_0 t); \quad 0 \leq t \leq T$$

and

$$s_2(t) = A \cos(2\pi f_0 t); \quad 0 \leq t \leq T$$

where  $f_0 = \frac{m}{T}$  where m is an integer.

- 16(B) Plot the above signal constellation and draw the decision region on it. Compute the probability of error. (7)K3

**Module IV**

- 17(A) Compute the probability of error for maximum likely hood detection of binary transmission. (8)K3
- 17(B) Explain the term matched filter. Plot the BER-SNR curve for a matched filter receiver (6)K2

**OR**

- 18(A) Design a zero forcing equalizer for the channel that is characterized by the filter taps  $\{1, 0.7, 0.3\}$  (8)K3
- 18(B) Explain partial response signaling (6)K2

**Module V**

- 19 For a shift keying system defined by  $s(t) = A_c k \sin(2\pi f_c t) \pm A_c k \cos(2\pi f_c t)$  plot the signal constellation. Compute the probability of error. (14)K3

**OR**

- 20(A) Derive the probability of error for a QPSK system with Gray coding. (10)K3
- 20(B) Draw the BER-SNR plot for a QPSK system (4)K3

**ECT 305 Analog and Digital Communication Simulation Assignments**

The following simulation assignments can be done with Python/MATLAB/SCILAB/LabVIEW The following simulations can be done in MATLAB, Python, R or LabVIEW.

**1 A-Law and  $\mu$ -Law Characteristics**

- Create a vector with say 1000 points that spans from  $-1$  to  $1$ .
- Apply A-Law companding on this vector get another vector. Plot it against the first vector for different A values and appreciate the transfer characteristics.
- Repeat the above steps for  $\mu$ -law as well.

**2 Practical A-Law compander**

- Implement the 8-bit practical A-law coder and decoder in Appendix B 2 (pp 583–585) in *Digital Telephony by Bellamy*
- Test it with random numbers and speech signals. Observe the 15 levels of quantization.

**3 Practical  $\mu$ -Law compander**

- Implement the 8-bit practical  $\mu$ -law coder and decoder in Appendix B 1 (pp 579–581) in *Digital Telephony by Bellamy*
- Test it with random numbers and speech signals. Observe the 15 levels of quantization.

**4 BPSK Transmitter and Receiver**

- Create a random binary sequence of 5000 bit. Convert it into a bipolar NRZ code.
- Create a BPSK mapper that maps bit 0 to zero phase and bit 1 to  $\pi$  phase.
- Plot the real part of the mapped signal against the imaginary part to observe the signal constellation
- Add AWGN of different variances to the base band BPSK signal and observe the changes in constellation.
- Realize the BPSK transmitter and receiver in Fig. 6.4 in page 352 in

*Communication Systems by Simon Haykin .*

- Add AWGN of different variances and compute the bit error rate (BER) for different SNR values.
- Plot the BER Vs. SNR.
- Plot the theoretical BER-SNR curve, using Eq. 6.19 in page 351 in *Communication Systems by Simon Haykin .*

## 5 QPSK Transmitter and Receiver

- Create a random binary sequence of 5000 bit. Convert it into a bipolar NRZ code.
- Create a QPSK mapper that maps bit patterns 00, 10, 11 and 01 to suitable phase values that are odd multiples of  $\frac{\pi}{4}$
- Plot the real part of the mapped signal against the imaginary part to observe the signal constellation
- Add AWGN of different variances to the base band QPSK signal and observe the changes in constellation.
- Realize the QPSK transmitter and receiver in Fig. 6.8 in page 359 in *Communication Systems by Simon Haykin .*
- Add AWGN of different variances and compute the bit error rate (BER) for different SNR values.
- Plot the BER Vs. SNR.
- Plot the theoretical BER-SNR curve, using Eq. 6.33 in page 358 in *Communication Systems by Simon Haykin .*

## 6 Matched Filter Receiver

The task is to develop a matched filter receiver, with zero ISI, as shown in the figure below.

- Generate 5000 random bits and up sample the stream by 4.
- For zero ISI, the impulse response of the transmitter and receiver filters are the RRC pulse with  $\alpha = 0.2$ .

$$p(t) = g(t) = \left(\frac{4\alpha}{\pi\sqrt{T}}\right) \left[ \frac{\cos(1+\alpha)\frac{\pi t}{T} + \frac{T}{4\alpha t} \sin(1-\alpha)\frac{\pi t}{T}}{1 - \left(\frac{4\alpha t}{T}\right)^2} \right] \quad (1)$$

- Plot  $p(t)$  and its approximate spectrum and appreciate.

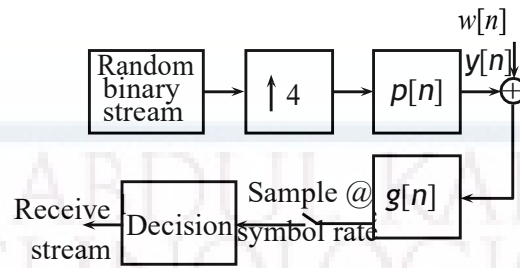

- Add AWGN ( $w[n]$ ) of different variances and compute the BER-SNR curve for the bit patterns received.

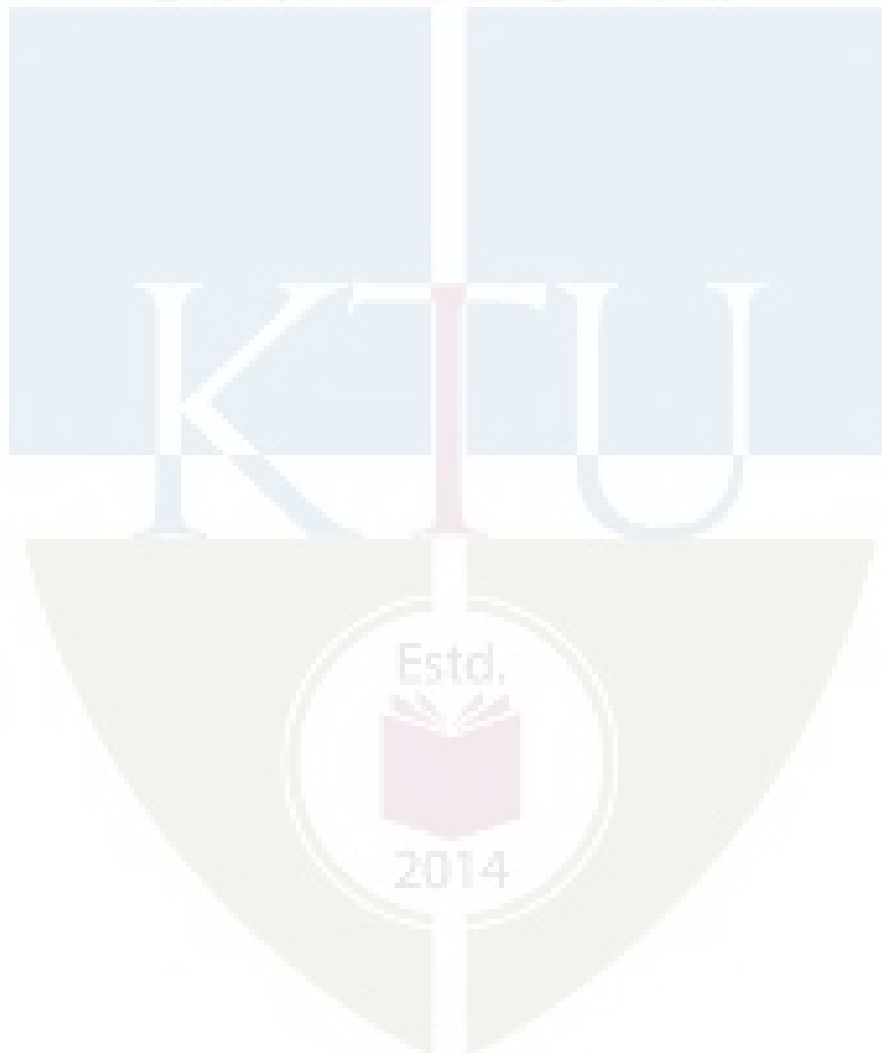

ECT307	CONTROL SYSTEMS	CATEGORY	L	T	P	CREDIT
		PCC	3	1	0	4

**Preamble:** This course aims to develop the skills for mathematical modelling of various control systems and stability analysis using time domain and frequency domain approaches.

**Prerequisite:** EC202 Signals & Systems

**Course Outcomes:** After the completion of the course the student will be able to

CO 1	Analyse electromechanical systems by mathematical modelling and derive their transfer functions
CO 2	Determine Transient and Steady State behaviour of systems using standard test signals
CO 3	Determine absolute stability and relative stability of a system
CO 4	Apply frequency domain techniques to assess the system performance and to design a control system with suitable compensation techniques
CO 5	Analyse system Controllability and Observability using state space representation

**Mapping of course outcomes with program outcomes**

	PO1	PO2	PO3	PO4	PO5	PO6	PO7	PO8	PO9	PO 10	PO 11	PO 12
CO 1	3	3	2		1							2
CO 2	3	3	2		1							2
CO 3	3	3	3		1							2
CO 4	3	3	3		1							2
CO 5	3	3	3		1							2

**Assessment Pattern**

Bloom's Category		Continuous Assessment Tests		End Semester Examination
		1	2	
Remember	K1	10	10	10
Understand	K2	20	20	20
Apply	K3	20	20	70
Analyse	K4			
Evaluate				
Create				

**Mark distribution**

<b>Total Marks</b>	<b>CIE</b>	<b>ESE</b>	<b>ESE Duration</b>
150	50	100	3 hours

**Continuous Internal Evaluation Pattern:**

Attendance	: 10 marks
Continuous Assessment Test (2 numbers)	: 25 marks
Assignment/Quiz/Course project	: 15 marks

**End Semester Examination Pattern:** There will be two parts; Part A and Part B. Part A contain 10 questions with 2 questions from each module, having 3 marks for each question. Students should answer all questions. Part B contains 2 questions from each module of which student should answer any one. Each question can have maximum 2 sub-divisions and carry 14 marks.

**Course Level Assessment Questions****Course Outcome 1 (CO1): Analyse electromechanical systems by mathematical modelling and derive their transfer functions**

1. For the given electrical/ mechanical systems determine transfer function.
2. Using block diagram reduction techniques find the transfer function of the given system.
3. Find the overall gain for the given signal flow graph using Mason's gain equation.

**Course Outcome 2 (CO2): Determine Transient and Steady State behaviour of systems using standard test signals**

1. Derive an expression for time response of a given first/ second order system to step/ ramp input.
2. Determine step, ramp and parabolic error constants for the given unity feedback control system.
3. Obtain the steady state error of a given system when subjected to an input.

**Course Outcome 3 (CO3): Determine absolute stability and relative stability of a system**

1. Using Ruth Hurwitz criterion, for the given control system determine the location of roots on S- plane and comment on the stability of the system.
2. Sketch the Root Locus for the given control system.



3. Compare P, PI and PID controllers.

**Course Outcome 4 (CO4): Apply frequency domain techniques to assess the system performance and to design a control system with suitable compensation techniques**

1. Explain frequency domain specifications.
2. Draw the Nyquist plot for the given control system and determine the range of K for which the system is stable.
3. Plot the bode plot for the given transfer function and find the gain margin and phase margin.
4. Describe the design procedure of a lag/ lead compensator.

**Course Outcome 5 (CO5): Analyse system Controllability and Observability using state space representation**

1. Obtain the state space representation of the given electrical/ mechanical system.
2. For the given control system, obtain the state equations and output equations:-
3. Plot the bode plot for the given transfer function and find the gain margin and phase margin.
4. Determine the controllability and observability of the given system.

## SYLLABUS

### Module 1:

**Introduction:** Basic Components of a Control System, Open-Loop Control Systems and Closed-Loop Control Systems, Examples of control system

**Feedback and its effects:** Types of Feedback Control Systems, Linear versus Nonlinear Control Systems, Time-Invariant versus Time-Varying Systems.

**Mathematical modelling of control systems:** Electrical Systems and Mechanical systems.

**Transfer Function from Block Diagrams and Signal Flow Graphs:** impulse response and its relation with transfer function of linear systems. Block diagram representation and reduction methods, Signal flow graph and Mason's gain formula.

### Module 2:

**Time Domain Analysis of Control Systems:** Introduction- Standard Test signals, Time response specifications.

Time response of first and second order systems to unit step input and ramp inputs, time domain specifications.

Steady state error and static error coefficients.

**Frequency domain analysis:** Frequency domain specifications, correlation between time and frequency responses.

### Module 3:

**Stability of linear control systems:** Concept of BIBO stability, absolute stability, Routh Hurwitz Criterion, Effect of P, PI & PID controllers.

**Root Locus Techniques:** Introduction, properties and its construction, Application to system stability studies. Illustration of the effect of addition of a zero and a pole.

### Module 4:

**Nyquist stability criterion:** Fundamentals and analysis

**Relative stability:** gain margin and phase margin. Stability analysis with Bode plot.

**Design of Compensators:** Need of compensators, design of lag and lead compensators using Bode plots.

### Module 5:

**State Variable Analysis of Linear Dynamic Systems:** State variables, state equations, state variable representation of electrical and mechanical systems, dynamic equations, merits for higher order differential equations and solution.

Transfer function from State Variable Representation, Solutions of the state equations, state transition matrix

Concept of controllability and observability and techniques to test them - Kalman's Test.

### Text Books

1. Farid Golnaraghi, Benjamin C. Kuo, Automatic Control Systems, 9/e, Wiley India.
2. I.J. Nagarath, M.Gopal: Control Systems Engineering (5th-Edition) —New Age International Pub. Co., 2007.
3. Ogata K., Discrete-time Control Systems, 2/e, Pearson Education.

### Reference Books

1. I.J. Nagarath, M.Gopal: Scilab Text Companion for Control Systems Engineering (3rd-Edition) —New Age International Pub. Co., 2007.
2. Norman S. Nise, Control System Engineering, 5/e, Wiley India.
3. M. Gopal, Digital Control and State Variable Method, 4/e, McGraw Hill Education India, 2012.
4. Ogata K., Modern Control Engineering, Prentice Hall of India, 4/e, Pearson Education, 2002.

5. Richard C Dorf and Robert H. Bishop, Modern Control Systems, 9/e, Pearson Education,2001.

### Course Contents and Lecture Schedule

No.	Topic	No. of Lectures
<b>1</b>	<b>Introduction</b>	
1.1	Basic Components of a Control System, Open-Loop Control Systems and Closed-Loop Control Systems, Examples of control system	1
1.2	<b>Feedback and its effects:</b> Types of Feedback Control Systems, Linear versus Nonlinear Control Systems, Time-Invariant versus Time-Varying Systems	2
1.3	<b>Mathematical modelling of control systems:</b> Electrical Systems and Mechanical systems	3
	<b>Transfer Function from Block Diagrams and Signal Flow Graphs</b>	
1.4	Impulse response and its relation with transfer function of linear systems. Block diagram representation and reduction methods	2
	Signal flow graph and Mason's gain formula	2
<b>2</b>	<b>Time Domain Analysis of Control Systems</b>	
2.1	Introduction- Standard Test signals, Time response specifications	2
2.2	Time response of first and second order systems to unit step input and ramp inputs, time domain specifications	3
2.3	Steady state error and static error coefficients	2
2.4	<b>Frequency domain analysis:</b> Frequency domain specifications, correlation between time and frequency responses.	2
<b>3</b>	<b>Stability of linear control systems</b>	
3.1	Stability of linear control systems: concept of BIBO stability, absolute stability, Routh's Hurwitz Criterion	3
3.2	Effect of P, PI & PID controllers	3
	<b>Root Locus Techniques</b>	
3.3	Introduction, properties and its construction, Application to system stability studies. Illustration of the effect of addition of a zero and a pole	3
<b>4</b>	<b>Nyquist stability criterion</b>	
4.1	Fundamentals and analysis	2
4.2	<b>Relative stability:</b> gain margin and phase margin. Stability analysis with Bode plot	3
4.3	<b>Design of Compensators:</b> Need of compensators, design of lag and lead compensators using Bode plots	4

5	<b>State Variable Analysis of Linear Dynamic Systems</b>	
5.1	State variables, state equations	3
5.2	State variable representation of electrical and mechanical systems	2
5.3	Dynamic equations, merits for higher order differential equations and solution	2
5.4	Transfer function from State Variable Representation, Solutions of the state equations, state transition matrix	2
5.5	Concept of controllability and observability and techniques to test them - Kalman's Test	4

### Simulation Assignments

The following simulations can be done in Python/ Scilab/ Matlab/ LabView:

1. Plot the pole-zero configuration in s-plane for the given transfer function.
2. Determine the transfer function for given closed loop system in block diagram representation.
3. Plot unit step response of given transfer function and find delay time, rise time, peak time and peak overshoot.
4. Determine the time response of the given system subjected to any arbitrary input.
5. Plot root locus of given transfer function, locate closed loop poles for different values of k.
6. Plot bode plot of given transfer function and determine the relative stability by measuring gain and phase margins.
7. Determine the steady state errors of a given transfer function.
8. Plot Nyquist plot for given transfer function and determine the relative stability.
9. Create the state space model of a linear continuous system.
10. Determine the state space representation of the given transfer function.

**Model Question paper****APJ ABDUL KALAM TECHNOLOGICAL UNIVERSITY**FIFTH SEMESTER B. TECH DEGREE EXAMINATION, **(Model Question Paper)****Course Code: ECT307****Course Name: CONTROL SYSTEMS**

Max. Marks: 100

Duration: 3 Hours

**PART A***Answer ALL Questions. Each Carries 3 mark.*

- 1 Draw the signal flow graph for the following set of algebraic equations: K2

$$x_1 = ax_0 + bx_1 + cx_2, \quad x_2 = dx_1 + ex_3$$

- 2 Using block diagram reduction techniques find  $C(s) / R(s)$  for the given system: K2

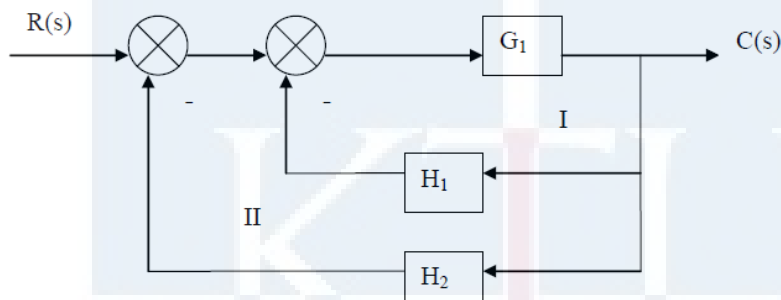

- 3 Derive the expression for peak time of a second order system K2
- 4 Determine the parabolic error constant for the unity feedback control system  $G(s) = 10(S+2)/(s+1)s^2$  K3
- 5 Using Routh Hurwitz criterion, determine the number of roots in the right half of S-plane for the system  $S^4 + 2S^3 + 10S^2 + 20S + 5 = 0$ . K3
- 6 Compare PI, PD and PID controllers. K1
- 7 State and explain Nyquist Stability criteria. K1
- 8 Briefly describe the design procedure of a lead compensator. K1
- 9 A dynamic system is represented by the state equation: K3

$$\dot{X} = \begin{bmatrix} 0 & 1 & 0 \\ 0 & 0 & 1 \\ 0 & -2 & -3 \end{bmatrix} X + \begin{bmatrix} 0 \\ 0 \\ 1 \end{bmatrix} r$$

Check whether the system is completely controllable.

10 Obtain the state space representation of the given electrical system:

K3

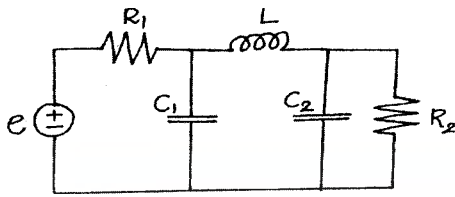

**PART - B**

Answer one question from each module; each question carries 14 marks.

**Module - I**

11a. Find the overall gain  $C(s)/R(s)$  for the signal flow graph shown using Mason's gain equation

7

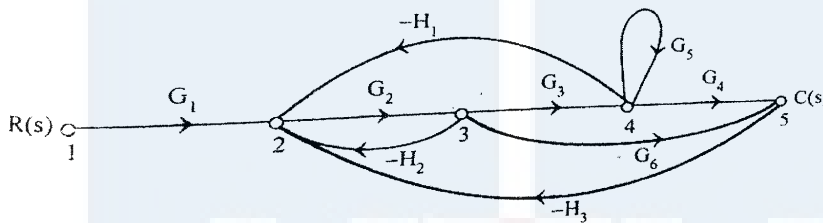

CO1  
K3

11b. Determine the transfer function  $X_1(s)/F(s)$  for the system shown below:

7

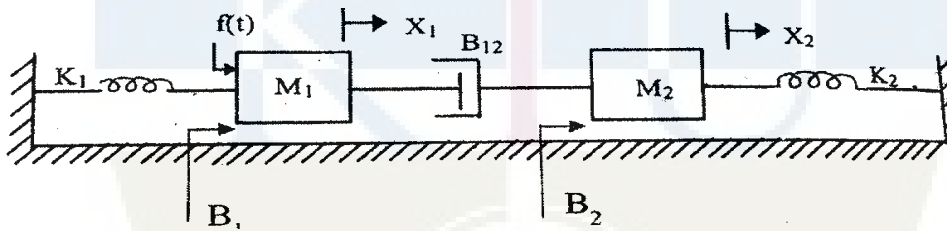

CO1  
K3

OR

12a. Find the transfer function  $X_2(s)/F(s)$ . Also draw the force voltage analogy of the given system:

8

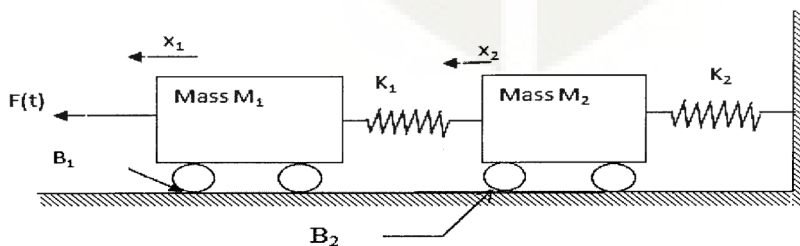

CO1  
K3

12b.

Determine the overall transfer function of the block diagram shown in below figure: 6

CO1  
K3

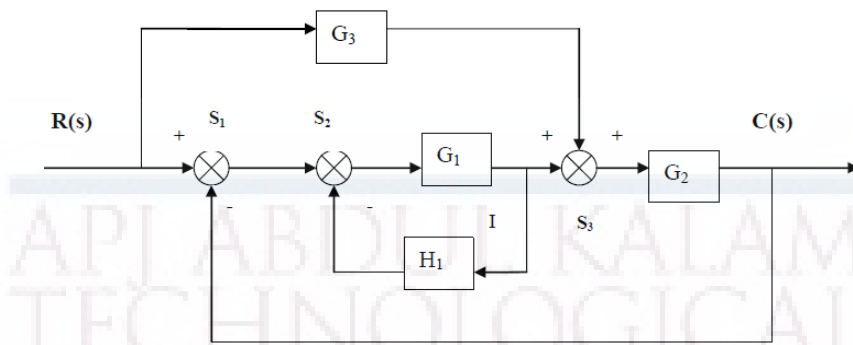

### Module - II

- 13a. The open loop transfer function of a servo system with unity feedback is  $G(s) = \frac{10}{s(0.1s+1)}$ . Evaluate the static error constants of the system. Obtain the steady state error of the system when subjected to an input given by  $r(t) = a_0 + a_1t + a_2t^2/2$  7  
CO2  
K2
- 13b. A unity feedback control system is characterized by an open loop transfer function  $G(s) = \frac{K}{s(s+10)}$ . Determine the gain K so that the system will have a damping ratio of 0.5 for this value of K. Determine the settling time, peak overshoot, rise time and peak time for a unit step input. 7  
CO2  
K2

OR

- 14a. Find  $k_p$ ,  $k_v$ ,  $k_a$  and steady state error for a system with open loop transfer function  $G(s)H(s) = \frac{15(s+4)(s+9)}{s(s+3)(s+6)(s+8)}$  7  
CO2
- 14b. Derive the expression for time response of a second order under damped system to step input. 7  
CO2  
K2

### Module - III

- 15a. Sketch the root locus for  $G(s)H(s) = \frac{K}{s(s+6)(s^2+4s+13)}$  7  
CO3  
K3
- 15b. The characteristic equation of a system is  $s^7 + 9s^6 + 24s^5 + 24s^4 + 24s^3 + 24s^2 + 23s + 15$ . Determine the location of roots on S- plane and hence comment on the stability of the system using Ruth Hurwitz criterion. 7  
CO3  
K3

OR



- 16a. Prove that the breakaway points of the root locus are the solutions of  $dK/ds = 0$ . 7  
 where K is the open loop gain of the system whose open loop transfer function is CO3  
 16b.  $G(s)$ . K2

- For a system with,  $F(s) = s^4 + 22s^3 + 10s^2 + s + K = 0$ . obtain the marginal value 7  
 17a. of K, and the frequency of oscillations of that value of K. CO3  
 K3

**Module - IV**

- 17b. Plot the bode diagram for the transfer function  $G(S) = 10 / S(1+0.4S)(1+0.1S)$  and 7  
 find the gain margin and phase margin. CO4  
 K3

The open loop transfer function of a feedback system is given by  $G(s) = K / s$  7  
 $(T1s+1)(T2s+1)$  Draw the Nyquist plot. Derive an expression for gain K in terms CO4  
 of T1, T2 and specific gain margin Gm. K3

**OR**

- 18a. A servomechanism has an open loop transfer function of  $G(s) = 10 / s(1+0.5s)$  8  
 $(1+0.1s)$  Draw the Bode plot and determine the phase and gain margin. A network CO4  
 having the transfer function  $(1+0.23s)/(1+0.023s)$  is now introduced in tandem. K3  
 Determine the new gain and phase margins. Comment upon the improvement in  
 system response caused by the network.

- 18b. Draw the Nyquist plot for the system whose open loop transfer function is 6  
 $G(s)H(s) = K / S(S+2)(S+10)$ . Determine the range of K for which the closed loop CO4  
 system is stable. K3

**Module - V**

- 19a. Obtain the state model for the given transfer function  $Y(s)/U(s) = 1/(S^2+S+1)$ . 7  
 CO5  
 K3

- 19b. What is transfer matrix of a control system? Derive the equation for transfer 7  
 matrix. CO5  
 2014 K2

**OR**

- 20a. A system is described by the transfer function  $Y(s)/U(s) = 10(s+4)/s(s+2)(s+3)$ . 7  
 Find state and output equations of the system. CO5  
 K3

- 20b. Determine the state transition matrix of 7  
 $A = \begin{bmatrix} 2 & 0 \\ -1 & 2 \end{bmatrix}$  CO5  
 K3



<b>ECL331</b>	<b>ANALOG INTEGRATED CIRCUITS AND SIMULATION LAB</b>	<b>CATEGORY</b>	<b>L</b>	<b>T</b>	<b>P</b>	<b>CREDIT</b>
		<b>PCC</b>	<b>0</b>	<b>0</b>	<b>3</b>	<b>2</b>

**Preamble:** This course aims to (i) familiarize students with the Analog Integrated Circuits and Design and implementation of application circuits using basic Analog Integrated Circuits (ii) familiarize students with simulation of basic Analog Integrated Circuits.

**Prerequisite:** ECL202 Analog Circuits and Simulation Lab

**Course Outcomes:** After the completion of the course the student will be able to

<b>CO 1</b>	Use data sheets of basic Analog Integrated Circuits and design and implement application circuits using Analog ICs.
<b>CO 2</b>	Design and simulate the application circuits with Analog Integrated Circuits using simulation tools.
<b>CO 3</b>	Function effectively as an individual and in a team to accomplish the given task.

**Mapping of course outcomes with program outcomes**

	PO1	PO 2	PO3	PO 4	PO5	PO 6	PO7	PO8	PO9	PO 10	PO 11	PO 12
<b>CO1</b>	3	3	3						2			2
<b>CO2</b>	3	3	3	2	3				2			2
<b>CO3</b>	2	2	2		2				3	2		3

**Assessment**

**Mark distribution**

<b>Total Marks</b>	<b>CIE</b>	<b>ESE</b>	<b>ESE Duration</b>
150	75	75	3 hours

**Continuous Evaluation Pattern**

Attendance : 15 marks  
 Continuous Assessment : 30 marks  
 Internal Test (Immediately before the second series test) : 30 marks

**End Semester Examination Pattern:** The following guidelines should be followed regarding award of marks

- |   |            |
|---|------------|
| (a) Preliminary work  | : 15 Marks |
| (b) Implementing the work/Conducting the experiment                               | : 10 Marks |
| (c) Performance, result and inference (usage of equipments and trouble shooting): | 25 Marks   |
| (d) Viva voce   | : 20 marks |
| (e) Record  | : 5 Marks  |

**General instructions:** End-semester practical examination is to be conducted immediately after the second series test covering entire syllabus given below. Evaluation is to be conducted under the equal responsibility of both the internal and external examiners. The number of candidates evaluated per day should not exceed 20. Students shall be allowed for the examination only on submitting the duly certified record. The external examiner shall endorse the record.

### Course Level Assessment Questions (Examples only)

**Course Outcome 1 (CO1):** Use data sheets of basic Analog Integrated Circuits and design and implement application circuits using Analog ICs.

1. Measure important opamp parameters of  $\mu A 741$  and compare them with the data provided in the data sheet
2. Design and implement a variable timer circuit using opamp
3. Design and implement a filter circuit to eliminate 50 Hz power line noise.

**Course Outcome 2 and 3 (CO2 and CO3):** Design and simulate the application circuits with Analog Integrated Circuits using simulation tools.

1. Design a precision rectifier circuit using opamps and simulate it using SPICE
2. Design and simulate a counter ramp ADC

### List of Experiments

- I. Fundamentals of operational amplifiers and basic circuits [Minimum seven experiments are to be done]
  1. Familiarization of Operational amplifiers - Inverting and Non inverting amplifiers, frequency response, Adder, Integrator, Comparators.
  2. Measurement of Op-Amp parameters.
  3. Difference Amplifier and Instrumentation amplifier.
  4. Schmitt trigger circuit using Op-Amps.
  5. Astable and Monostable multivibrator using Op-Amps.
  6. Waveform generators using Op-Amps - Triangular and saw tooth
  7. Wien bridge oscillator using Op-Amp - without & with amplitude stabilization.

8. RC Phase shift Oscillator.
9. Active second order filters using Op-Amp (LPF, HPF, BPF and BSF).
10. Notch filters to eliminate the 50Hz power line frequency.
11. Precision rectifiers using Op-Amp.

**II. Application circuits of 555 Timer/565 PLL/ Regulator(IC 723) ICs [ Minimum three experiments are to be done]**

1. Astable and Monostable multivibrator using Timer IC NE555
2. DC power supply using IC 723: Low voltage and high voltage configurations, Short circuit and Fold-back protection.
3. A/D converters- counter ramp and flash type.
4. D/A Converters - R-2R ladder circuit
5. Study of PLL IC: free running frequency lock range capture range

**III. Simulation experiments [The experiments shall be conducted using SPICE]**

1. Simulation of any three circuits from Experiments 3, 5, 6, 7, 8, 9, 10 and 11 of section I
2. Simulation of Experiments 3 or 4 from section II

**Textbooks**

1. D. Roy Choudhary, Shail B Jain, "Linear Integrated Circuits,"
2. M. H. Rashid, "Introduction to Pspice Using Orcad for Circuits and Electronics", Prentice Hall



<b>ECL333</b>	<b>DIGITAL SIGNAL PROCESSING LABORATORY</b>	<b>CATEGORY</b>	<b>L</b>	<b>T</b>	<b>P</b>	<b>CREDIT</b>
		<b>PCC</b>	<b>0</b>	<b>0</b>	<b>3</b>	<b>2</b>

**Preamble:**

- The following experiments are designed to make the student do real time DSP computing.
- Dedicated DSP hardware (such as TI or Analog Devices development/evaluation boards) will be used for realization.

**Prerequisites:**

- ECT 303 Digital Signal Processing
- EST 102 Programming in C

**Course Outcomes:** The student will be able to

<b>CO 1</b>	Simulate digital signals.
<b>CO 2</b>	verify the properties of DFT computationally
<b>CO 3</b>	Familiarize the DSP hardware and interface with computer.
<b>CO 4</b>	Implement LTI systems with linear convolution.
<b>CO 5</b>	Implement FFT and IFFT and use it on real time signals.
<b>CO 6</b>	Implement FIR low pass filter.
<b>CO 7</b>	Implement real time LTI systems with block convolution and FFT.

**Mapping of Course Outcomes with Program Outcomes**

	<b>PO 1</b>	<b>PO 2</b>	<b>PO 3</b>	<b>PO 4</b>	<b>PO 5</b>	<b>PO 6</b>	<b>PO 7</b>	<b>PO 8</b>	<b>PO 9</b>	<b>PO1 0</b>	<b>PO1 1</b>	<b>PO1 2</b>
<b>CO1</b>	3	3	1	2	3	0	0	0	3	0	0	1
<b>CO2</b>	3	3	1	2	3	0	0	0	3	0	0	1
<b>CO3</b>	3	3	3	2	3	0	0	0	3	1	0	1
<b>CO4</b>	3	3	1	2	3	0	0	0	3	0	0	1
<b>CO5</b>	3	3	1	1	3	0	0	0	0	0	0	1
<b>CO6</b>	3	3	1	1	3	0	0	0	0	0	0	1
<b>CO7</b>	3	3	1	3	3	0	0	0	3	3	0	0

**Assessment Pattern****Mark Distribution:**

Total Mark	CIE	ESE
150	50	100

**Continuous Internal Evaluation Pattern:**

Each experiment will be evaluated out of 50 credits continuously as

Attribute	Mark
Attendance	15
Continuous assessment	30
Internal Test (Immediately before the second series test)	30

**End Semester Examination Pattern:** The following guidelines should be followed regarding award of marks

Attribute	Mark
Preliminary work	15
Implementing the work/ Conducting the experiment	10
Performance, result and inference (usage of equipments and trouble shooting)	25
Viva voce	20
Record	5

**Course Level Assessment Questions****CO1-Simulation of Signals**

1. Write a Python/MATLAB/SCILAB function to generate a rectangular pulse.
2. Write a Python/MATLAB/SCILAB function to generate a triangular pulse.

**CO2-Verification of the Properties of DFT**

1. Write a Python/MATLAB/SCILAB function to compute the  $N$ -point DFT

matrix and plot its real and imaginary parts.

2. Write a Python/MATLAB/SCILAB function to verify Parseval's theorem for  $N = 1024$ .

### **CO3-Familiarization of DSP Hardware**

1. Write a C function to control the output LEDs with input switches.
2. Write a C function to connect the analog input port to the output port and test with a microphone.

### **CO4-LTI System with Linear Convolution**

1. Write a function to compute the linear convolution and download to the hardware target and test with some signals.

### **CO5-FFT Computation**

1. Write and download a function to compute N point FFT to the DSP hardware target and test it on real time signal.
2. Write a C function to compute IFFT with FFT function and test in on DSP hardware.

### **CO6-Implementation of FIR Filter**

1. Design and implement an FIR low pass filter for a cut off frequency of  $0.1\pi$  and test it with an AF signal generator.

### **CO7-LTI Systems by Block Convolution**

1. Implement an overlap add block convolution for speech signals on DSP target.

## List of Experiments

(All experiments are mandatory.)

**Experiment 1. Simulation of Signals** Simulate the following signals using Python/Scilab/MATLAB.

1. Unit impulse signal
2. Unit pulse signal
3. Unit ramp signal
4. Bipolar pulse
5. Triangular signal

**Experiment 2. Verification of the Properties of DFT**

- Generate and appreciate a DFT matrix.
  1. Write a function that returns the  $N$  point DFT matrix  $\mathbf{V}_N$  for a given  $N$ .
  2. Plot its real and imaginary parts of  $\mathbf{V}_N$  as images using *matshow* or *imshow* commands (in Python) for  $N = 16$ ,  $N = 64$  and  $N = 1024$
  3. Compute the DFTs of 16 point, 64 point and 1024 point random sequences using the above matrices.
  4. Observe the time of computations for  $N = 2^\gamma$  for  $2 \leq \gamma \leq 10$  (You may use the *time* module in Python).
  5. Use some iterations to plot the times of computation against  $\gamma$ . Plot and understand this curve. Plot the times of computation for the *fft* function over this curve and appreciate the computational saving with FFT.
- Circular Convolution.
  1. Write a python function *circonv.py* that returns the circular convolution of an  $N_1$  point sequence and an  $N_2$  point sequence given at the input. The easiest way is to convert a linear convolution into circular convolution with  $N = \max(N_1, N_2)$ .
- Parseval's Theorem  
For the complex random sequences  $x_1[n]$  and  $x_2[n]$ ,

$$\sum_{n=0}^{N-1} x_1[n]x_2^*[n] = \frac{1}{N} \sum_{k=0}^{N-1} X_1[k]X_2^*[k]$$

1. Generate two random complex sequences of say 5000 values.
2. Prove the theorem for these signals.

### **Experiment 3. Familiarization of DSP Hardware**

1. Familiarization of the code composer studio (in the case of TI hardware) or Visual DSP (in the case of Analog Devices hardware) or any equivalent cross compiler for DSP programming.
2. Familiarization of the analog and digital input and output ports of the DSP board.
3. Generation and cross compilation and execution of the C code to connect the input digital switches to the output LEDs.
4. Generation and cross compilation and execution of the C code to connect the input analog port to the output. Connect a microphone, speak into it and observe the output electrical signal on a DSO and store it.
5. Document the work.

### **Experiment 4. Linear convolution**

1. Write a C function for the linear convolution of two arrays.
2. The arrays may be kept in different files and downloaded to the DSP hardware.
3. Store the result as a file and observe the output.
4. Document the work.

### **Experiment 5. FFT of signals**

1. Write a C function for N - point FFT.
2. Connect a precision signal generator and apply  $1\text{ mV}$ ,  $1\text{ kHz}$  sinusoid at the analog port.
3. Apply the FFT on the input signal with appropriate window size and observe the result.
4. Connect microphone to the analog port and read in real time speech.
5. Observe and store the FFT values.
6. Document the work.



**Experiment 6. IFFT with FFT**

1. Use the FFT function in the previous experiment to compute the IFFT of the input signal.
2. Apply IFFT on the stored FFT values from the previous experiments and observe the reconstruction.
3. Document the work.

**Experiment 7. FIR low pass filter**

1. Use Python/scilab to implement the FIR filter response  $h[n] = \frac{\sin(\omega_c n)}{\pi n}$  for a filter size  $N = 50$ ,  $\omega_c = 0.1\pi$  and  $\omega_c = 0.3\pi$ .
2. Realize the hamming( $w_H[n]$ ) and kaiser ( $w_K[n]$ ) windows.
3. Compute  $h[n]w[n]$  in both cases and store as file.
4. Observe the low pass response in the simulator.
5. Download the filter on to the DSP target board and test with 1 mV sinusoid from a signal generator connected to the analog port.
6. Test the operation of the filters with speech signals.
7. Document the work.

**Experiment 8. Overlap Save Block Convolution**

1. Use the file of filter coefficients From the previos experiment.
2. Realize the system shown below for the input speech signal  $x[n]$ .

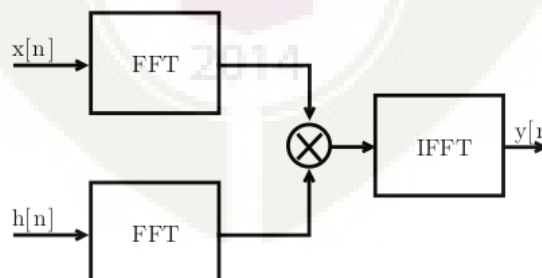

3. Segment the signal values into blocks of length  $N = 2000$ . Pad the last

block with zeros, if necessary.

4. Implement the *overlap save* block convolution method
5. Document the work.

### Experiment 9. Overlap Add Block Convolution

1. Use the file of filter coefficients from the previous experiment.
2. Realize the system shown in the previous experiment for the input speech signal  $x[n]$ .
3. Segment the signal values into blocks of length  $N = 2000$ . Pad the last block with zeros, if necessary.
4. Implement the *overlap add* block convolution method
5. Document the work.

**Schedule of Experiments:** Every experiment should be completed in three hours.

### Textbooks

1. Vinay K. Ingle, John G. Proakis, "Digital Signal Processing Using MATLAB."
2. Allen B. Downey, "Think DSP: Digital Signal Processing using Python."
3. Rulph Chassaing, "DSP Applications Using C and the TMS320C6x DSK (Topics in Digital Signal Processing)"

APJ ABDUL KALAM  
TECHNOLOGICAL  
UNIVERSITY

**SEMESTER V**

**MINOR**

KTU



ECT381	EMBEDDED SYSTEM DESIGN	CATEGORY	L	T	P	CREDI T
		PCC	3	1	0	4

**Preamble:** This course aims to design an embedded electronic circuit and implement the same.

**Prerequisite:** ECT203 Logic Circuit Design, ECT206 Computer Architecture and Microcontrollers

**Course Outcomes:** After the completion of the course the student will be able to

<b>CO 1 K2</b>	Understand and gain the basic idea about the embedded system.
<b>CO 2 K3</b>	Able to gain architectural level knowledge about the system and hence to program an embedded system.
<b>CO 3 K3</b>	Apply the knowledge for solving the real life problems with the help of an embedded system.

**Mapping of course outcomes with program outcomes**

	PO 1	PO 2	PO 3	PO 4	PO 5	PO 6	PO 7	PO 8	PO 9	PO 10	PO 11	PO 12
<b>CO 1</b>	3	3	2		1			2				2
<b>CO 2</b>	3	3	3		3			2				2
<b>CO 3</b>	3	3	3		3			2	3			2

**Assessment Pattern**

Bloom's Category		Continuous Assessment Tests		End Semester Examination
		1	2	
Remember	K1	10	10	10
Understand	K2	20	20	20
Apply	K3	20	20	70
Analyse				
Evaluate				
Create				

**Mark distribution**

<b>Total Marks</b>	<b>CIE</b>	<b>ESE</b>	<b>ESE Duration</b>
150	50	100	3 hours

**Continuous Internal Evaluation Pattern:**

Attendance	: 10 marks
Continuous Assessment Test (2 numbers)	: 25 marks
Assignment/Quiz/Course project	: 15 marks

**End Semester Examination Pattern:** There will be two parts; Part A and Part B. Part A contain 10 questions with 2 questions from each module, having 3 marks for each question. Students should answer all questions. Part B contains 2 questions from each module of which student should answer any one. Each question can have maximum 2 sub-divisions and carry 14 marks.

**Course Level Assessment Questions**

**Course Outcome 1 (CO1) : Understand the embedded system fundamentals and system design (K1).**

1. Give the challenges of embedded computing..
2. Give the structural description of embedded system.
3. What are the phases of EDLC?

**Course Outcome 2 (CO2): Understand the peripheral devices and their interfacing with the processor. (K2)**

1. Compare and contrast the PCI bus and PCI-X bus.
2. How the ROM memories are classified? Explain.
3. How the peripheral devices are connected with processors?

**Course Outcome 3 (CO3): To write programs using high level languages for embedded systems. (K3)**

1. Write an embedded C program for sorting 64 numbers stored in memory locations and find the smallest and largest number.
2. How the functions are called by using pointers in embedded 'C' ? Discuss with the help of examples.
3. Give the features of Object Oriented Programming.

**Course Outcome 4 (CO4): To understand the ARM processor architecture and pipeline processor organization. (K2)**

1. Give the architecture of the ARM processor and explain the registres.
2. Explain the pipelined architecture of ARM processor.
3. Write an ARM assembly language program to print the sum of two numbers.

**Course Outcome 5 (CO5): To write programs in assembly and high level languages for ARM processor. (K3)**

1. Write a note on Thumb single register in ARM processor.
2. Briefly discuss about the Advanced Microcontroller Bus Architecture (AMBA).
3. What are the data types supported by ARM programming high level languages.

**SYLLABUS**

**Module 1 : Introduction to Embedded Systems( 08 Hours )**

**1.1 Complex Systems and Microprocessors**

Embedding Computers, Characteristics of Embedded Computing Applications, Application of Microprocessors, The Physics of Software, Challenges in Embedded Computing System, Characteristics and quality attributes of an embedded system, Performance in Embedded Computing

**1.2 The Embedded System Design Process**

Requirements, Specification , Architecture Design, Designing Hardware and Software Components and System Integration.

**1.3 Formalisms for System Design**

Structural Description, Behavioral Description, An embedded system design example.

**1.4 Embedded product development cycle (EDLC)**

Different phases of EDLC and EDLC models

**Module 2 : Embedded system interfacing and peripherals (09Hours)**

**2.1 Communication devices**

Serial Communication Standards and Devices - UART, HDLC and SPI. Serial Bus Protocols - I<sup>2</sup>C Bus, CAN Bus and USB Bus, Parallel communication standards-ISA, PCI and PCI-X Bus.

**2.2 Memory**

Memory devices and systems :- ROM-Flash, EEPROM: RAM-SRAM, DRAM, Cache memory, memory mapping and addresses, memory management unit- DMA .

**2.3 I/O Device**

Interrupts:-Interrupt sources, recognizing an interrupt, ISR – Device drivers for handling ISR, Shared data problem, Interrupt latency.

**Module 3 : Embedded Programming( 11 Hours)**

**3.1 Programming languages:-** Assembly Languages, High level languages, Embedded C, Object oriented programming, C++, JAVA.

**3.2 Embedded C programming:-** Keywords and Identifiers, Data Types, Storage Class, operators, branching, looping, arrays, pointers, characters, strings, functions, function pointers, structures, unions, pre-processors and macros, constant declaration, volatile type qualifier, delay generation, infinite loops, bit manipulation, ISR, direct memory allocation

**Module 4 : ARM Processor fundamentals (07 Hours )**

**4.1 ARM Processor architecture:-**The Acorn RISC Machine- Architectural inheritance, The ARM programmer's model, ARM development tools.

**4.2 ARM Assembly Language Programming:-**Data processing instructions, Data transfer instructions, Control flow instructions, writing simple assembly language programs.

**4.3 ARM Organization and Implementation:-**3 stage pipeline ARM organization, 5-stage pipeline ARM organization, ARM instruction execution, ARM implementation, The ARM coprocessor interface

**Module 5: ARM Programming (10 Hours)**

**5.1 Architectural Support for High Level Languages :-**Abstraction in software design, Data types, Floating-point data types, The ARM floating-point architecture, Expressions, Conditional statements, Loops, Functions and procedures, Use of memory, Run-time environment.

**5.2 The Thumb Instruction Set :-**The Thumb bit in the CPSR, The Thumb programmer's model, Thumb branch instructions, Thumb software interrupt instruction, Thumb data processing instructions, Thumb single register data transfer instructions, Thumb multiple register data transfer instructions, Thumb breakpoint instruction, Thumb implementation, Thumb applications.

**5.3 Architectural Support for System Development:-** The ARM memory interface, The Advanced Microcontroller Bus Architecture (AMBA).

**Text Books**

1. Raj kamal, Embedded Systems Architecture, Programming and Design, TMH, 2003
2. K.V. Shibu, Introduction to Embedded Systems, 2e, McGraw Hill Education India, 2016.
3. Wayne Wolf, Computers as Components: Principles of Embedded Computing System Design, Morgan Kaufman Publishers - Elsevier 3ed, 2008
4. Steve Furber, ARM system-on-chip architecture, Addison Wesley, Second Edition, 2000

## Reference Books

1. David E. Simon, An Embedded Software Primer, Pearson Education Asia, First Indian Reprint 2000.
2. Steve Heath, Embedded Systems Design, Newnes – Elsevier 2ed, 2002
3. Andrew N. Sloss, Dominic Symes, Chris Wright, ARM System Developer's Guide Designing and Optimizing System Software, Morgan Kaufmann Publishers 2004
4. Frank Vahid and Tony Givargis, Embedded Systems Design – A Unified Hardware / Software Introduction, John Wiley, 2002.
5. Tammy Noergaard, Embedded Systems Architecture, A Comprehensive Guide for Engineers and Programmers, Newnes – Elsevier 2ed, 2012
6. Iyer - Embedded Real time Systems, 1e, McGraw Hill Education New Delhi, 2003
7. Lyla B. Das, Embedded Systems: An Integrated Approach, 1/e , Lyla B. Das, Embedded Systems, 2012

## Course Contents and Lecture Schedule

No	Topic	No. of Lectures
<b>1</b>	<b>Introduction to Embedded Systems</b>	
1.1	Complex Systems and Microprocessors	3
1.2	The Embedded System Design Process	1
1.3	Formalisms for System Design	2
1.4	Embedded product development cycle (EDLC)	2
<b>2</b>	<b>Embedded system interfacing and peripherals</b>	
2.1	Communication devices	3
2.2	Memory	3
2.3	I/O Device	3
<b>3</b>	<b>Embedded Programming</b>	
3.1	Programming languages	1
3.2	Embedded C programming	10
<b>4</b>	<b>ARM Processor</b>	
4.1	ARM Processor architecture	2
4.2	ARM Assembly Language Programming	3
4.3	ARM Organization and Implementation	2
<b>5</b>	<b>ARM Programming</b>	
5.1	Architectural Support for High-Level Languages	4
1	The Thumb Instruction Set	4
5.3	Architectural Support for System Development	2



**Simulation Assignments:**

1. At least one assignment should be of programming (Both assembly and C languages) of embedded processor with simulation tools like Keil, Eclipse.
2. Another assignment should be an embedded system design mini project like, Programming assignments can be the following
  - a) Print “HELLO WORLD” or any text, b)Data transfer, copy operations c)Arithmetic operations d)Sorting operations, e)Input/output control, f)Programs using functions, g) Interrupts and ISR h) controller design
3. Mini project can be done in the following areas.
  - a) Elevator controller design (b) Chocolate vending machine design (c) Industrial controller using sensors (d) IOT applications using sensors, communication devices and actuators

**Model Question paper****APJ ABDUL KALAM TECHNOLOGICAL UNIVERSITY**FIFTH SEMESTER B.TECH DEGREE EXAMINATION, (**Model Question Paper**)**Course Code: ECT381****Course Name: EMBEDDED SYSTEM DESIGN**

Max. Marks: 100

Duration: 3 Hours

**PART A**

(Answer for all questions. Each Question Carries 3 marks)

1. Define an embedded system
2. Write any three challenges of embedded system design
3. Explain how an RS232 device is interfaced to a processor
4. What is interrupt latency?
5. What are the differences between assembly level language and high level language?
6. What is the difference between macros and functions?
7. Write the contents of CPSR register of ARM processor and their use.
8. Draw the five stage pipeline architecture of ARM processor
9. What is the use of thumb instruction set in ARM processor?
10. Write a note on ARM memory interface.

[ 10 X 3 = 30 Marks]

**PART – B**

(Answer one question from each module; each question carries 14 Marks)

**Module – I**

11. a). What are the characteristics of an embedded system? Explain. [07 Marks]  
 b). Explain the different phases of EDLC. [07 Marks]

**OR**

- (a) Write different steps involved in the embedded system design process. [07 Marks]  
 (b) Explain the structural description of embedded system design. [07 Marks]

**Module – II**

12. (a) What is serial and parallel port communication? Explain with the help of necessary diagrams. [07 Marks]  
 (b) What is interrupt? How interrupts are handled in a processor? Explain ISR. [07 Marks]

**OR**

13. (a) With the help of a diagram show how ROM and RAM are interfaced to a processor. Explain the read/write processes. [07 Marks]  
 (b) Explain how a memory management unit is used in a processor. What are its uses? What is DMA ? [07 Marks]

**Module – III**

14. (a) What are the advantages and disadvantage of object oriented programming like C++ and Java. [07 Marks]  
 (b) Write an embedded C program for adding 64 numbers stored in memory locations and find the average of the same. [07 Marks]

**OR**

15. (a) What is pre-processor directive? How is a pre-processor directive instruction differentiated from normal program code? What are the different types of pre-processor directives available in 'Embedded C'? [07 Marks]  
 (b) Write an embedded C program to perform addition, subtraction, multiplication and division operations of 2 numbers stored in specific memory locations using a mode control. [07 Marks]

**Module – IV**

16. (a) Write a note on ARM processor architecture and its registers. [07 Marks]  
(b) Write a note on data processing and data transfer instructions with the help of examples. [07 Marks]

**OR**

17. (a) What is pipelined architecture? Explain how an ARM instruction is executed in a five stage pipeline processor with the help of an example. [08 Marks]  
(b) Write an ARM assembly language program to print text string “Hello World” .[06Marks]

**Module – V**

18. (a) Explain ARM floating point architecture and discuss how floating point numbers are handled. [07 Marks]  
(b) Write a note on Thumb single register and multiple register data transfer instructions with the help of examples. [07 Marks]

**OR**

19. (a) What is Thumb instruction set? Why it is used? Explain Thumb programmers model. [07 Marks]  
(b) Draw the block diagram of AMBA architecture. What are the different types of buses used in this architecture? [07 Marks]

Estd.



2014

ECT383	COMMUNICATION SYSTEMS	CATEGORY	L	T	P	CREDIT
		VAC	3	1	0	4

**Preamble:** The objective of this course to get awareness about various communication systems using in practice.

**Prerequisite:** NIL

**Course Outcomes:** After the completion of the course the student will be able to

CO1	Explain the components required for an Optical Communication Systems
CO2	Discuss the principle involved in RADAR and Navigation
CO3	Explain the concept and subsystems for Cellular Communication networks
CO4	Outline the requirement for Satellite communication systems
CO5	Discuss the role of different layers in TCP/IP protocol stack in communication networks

#### Mapping of course outcomes with program outcomes

	PO1	PO2	PO3	PO4	PO5	PO6	PO7	PO8	PO9	PO10	PO11	PO12
CO1	3	3										
CO2	3	3										
CO3	3	3										
CO4	3	3										
CO5	3	3										
CO6	3	3										

#### Assessment Pattern

Bloom's Category	Continuous Assessment Test		End Semester Examination
	1	2	
Remember, K1	10	10	10
Understand, K2	20	20	40
Apply, K3	20	20	50
Analyze			
Evaluate			
Create			

#### Mark Distribution

Total Marks	CIE	ESE	ESE Duration
150	50	100	3 hours

**Continuous Internal Evaluation Pattern:**

Attendance : 10 marks

Continuous Assessment Test (2 numbers) : 25 marks

Assignment/Quiz/Course project : 15 marks

**End Semester Examination Pattern:** There will be two parts; Part A and Part B. Part A contain 10 questions with 2 questions from each module, having 3 marks for each question. Students should answer all questions. Part B contains 2 questions from each module of which student should answer any one. Each question can have maximum 2 sub-divisions and carry 14 marks.

**Course Level Assessment Questions**

**Course Outcome 1 (CO1):** Explain the components required for an Optical Communication Systems

1. Explain the block diagram for Optical Communication Systems
2. Distinguish between step index and graded index fiber
3. Explain various attenuations occurring in optical fiber

**Course Outcome 2 (CO2):** Discuss the principle involved in RADAR and Navigation

1. Explain Radar range equation and how the range of a radar system is increased?
2. Explain the block diagram for pulsed radar system
3. Explain Instrument landing system

**Course Outcome 3 (CO3):** Explain the concept and subsystems for Cellular Communication networks

1. What is frequency reuse?
2. Explain the principle of multicarrier communication
3. Explain GSM architecture

**Course Outcome 4 (CO4):** Outline the requirement for Satellite communication systems

1. Explain the block diagram for satellite uplink
2. What are geostationary satellites?
3. Explain various satellite orbits

**Course Outcome 5 (CO5):** Discuss the issues, challenges and architecture for various wireless ad hoc networks

1. Explain the issues and challenges of Wireless Ad Hoc Networks
2. What is 6LoWPAN?
3. Explain the function of each layer of TCP/IP protocol stack

## Syllabus

### Module 1 (Optical Communication)

Optical Communication System – Block Diagram – Advantages Of Optical Fiber Communication Systems – Principles Of Light Transmission In A Fiber Using Ray Theory – Single Mode Fibers, Multimode Fibers – Step Index Fibers, Graded Index Fibers (Basic Concepts Only) – Attenuation In Optical Fibers – Absorption Losses, Scattering Losses, Bending Losses, Core And Cladding Losses. **Optical transmitters:** LED and semiconductor LASER, characteristics, transmitter design. **Optical receivers:** Common photo detectors. Receiver design

### Module 2 (Radar and Navigation)

Basic Radar System– Applications – Radar Range Equation (Qualitative Treatment Only) – Factors Influencing Maximum Range – Basic Pulsed Radar System – Block Diagram – Display Methods- A - Scope, PPI Display - Instrument Landing System – Ground Controlled Approach System.

### Module 3 (Cellular Communication)

Cellular Communication, Hand off, Frequency Reuse, Principles of Multicarrier communication, Multiple Access techniques, CDMA Systems: General aspects of CDMA cellular systems, IS-95 standard, Downlink and uplink, GSM standard and service aspects – GSM architecture, Evolution to Third Generation systems, WCDMA and CDMA-2000 standards, 4G, 5G

### Module 4 (Satellite Communication)

Basic concept of satellite communication, Kepler's law, Satellite orbits, Geosynchronous satellites, Active and Passive satellite, Block diagram for Satellite uplink, Transponder and earth station receiver

### Module 5 (Data Communication and Networks)

Study of OSI and TCP/IP protocol suit: The Model, Functions of each layer, TCP/IP Protocol Suites. Wireless Ad Hoc Networks: Issues and Challenges, Wireless Sensor Networks: Architecture, Data dissemination, Data gathering, MAC Protocols, Location discovery, Quality of a sensor network 6LoWPAN

### Textbooks

1. Electronic communication system fundamentals Wayne Tomasi, Pearson Education.
2. Data Communication and Networking by Behrouz A. Forouzan (Fourth Edition), Tata McGraw Hill

### References

1. Wireless communication principles and practice T S Rappaport, Pearson Education.
2. G. E. Keiser – Optical Fibre Communication – Mc Graw Hill Publication.
3. D. C. Agarwal – Satellite Communication – Khanna Publications

4. Jochen Schiller - Mobile Communications- Pearson Education
5. Siva ram Murthy, B S Manoj- Ad Hoc Wireless Networks – Printice Hall

### Course Contents and Lecture Schedule

Sl No	Topic	No.of Lecture hours
1.1	<b>Module 1</b> Optical Communication System – Block Diagram – Advantages Of Optical Fiber Communication Systems – Principles Of Light Transmission In A Fiber Using Ray Theory – Single Mode Fibers, Multimode Fibers – Step Index Fibers, Graded Index Fibers (Basic Concepts Only) – Attenuation In Optical Fibers – Absorption Losses, Scattering Losses, Bending Losses, Core And Cladding Losses.	4
1.2	<b>Optical transmitters:</b> LED and semiconductor LASER, characteristics, transmitter design. <b>Optical receivers:</b> Common photo detectors. Receiver design	4
2.1	<b>Module 2</b> Basic Radar System– Applications – Radar Range Equation (Qualitative Treatment Only) – Factors Influencing Maximum Range – Basic Pulsed Radar System – Block Diagram – Display Methods- A - Scope, PPI Display	4
2.2	Instrument Landing System – Ground Controlled Approach System.	3
3.1	<b>Module 3</b> Cellular Communication, Hand off, Frequency Reuse, Principles of Multicarrier communication, Multiple Access techniques, CDMA Systems: General aspects of CDMA cellular systems, IS-95 standard, Downlink and uplink	5
3.2	GSM standard and service aspects – GSM architecture, Evolution to Third Generation systems, WCDMA and CDMA-2000 standards,4G, 5G	5
4.1	<b>Module 4</b> Basic concept of satellite communication, Keppler’s law, Satellite orbits, Geosynchronous satellites	3
4.2	Active and Passive satellite, Block diagram for Satellite uplink, Transponder and earth station receiver	4
5.1	<b>Module 5</b> Study of OSI and TCP/IP protocol suit: The Model, Functions of each layer, TCP/IP Protocol Suites.	4
5.2	Issues and challenges in Wireless Ad Hoc Networks, Vehicular Ad Hoc Networks	2
5.3	Wireless Sensor Networks: Architecture, Data dissemination, Data gathering, MAC Protocols, Location discovery, Quality of a sensor network, 6LoWPAN	5



**Sample Assignments**

1. Explain the block diagram for optical communication systems
2. Write Radar range equation
3. Distinguish between A scope display and PPP display
4. Distinguish between step index and graded index fiber
5. Write Kepler's law for planetary motion

**APJ ABDUL KALAM TECHNOLOGICAL UNIVERSITY**  
**FIFTH SEMESTER B.TECH. DEGREE EXAMINATION**  
**ECT 383: Communication Systems**

Max. Marks: 100

Duration: 3hours

**PART A***(Answer all questions. Each question carries 3 marks each.)*

1. Compare the advantages and disadvantages of fiber-optic cables and metallic cables
2. Define Numerical Aperture
3. Write the RADAR range equation
4. Explain the principle of A-scope display
5. Why a honeycomb pattern was is selected for cell area?
6. Distinguish between soft handoff and hard handoff
7. Define Apogee and Perigee
8. Define look angles, angle of elevation and azimuth
9. List the challenges of wireless ad hoc networks
10. Explain 3-way handshaking

**PART B***(Answer any one question from each module. Each question carries 14 marks.)***Module 1**

11. (a) Explain different losses in Optical Fiber cable  
(b) Explain the operation of LED
12. (a) Explain the block diagram for Optical Fiber Communication  
(b) Explain the function of photodiode

**Module 2**

13. Explain the block diagram for pulsed RADAR
14. Explain the principle of PPI display

**Module 3**

15. Explain the architecture for GSM
16. Explain block diagram for CDMA system

**Module 4**

17. Explain Kepler's law of planetary motion
18. Explain the block diagram for satellite transponder

**Module 5**

19. Explain the role of each layer in TCP/IP protocol stack
20. Explain various data dissemination protocols used in wireless sensor networks



ECT385	TOPICS IN DIGITAL IMAGE PROCESSING	CATEGORY	L	T	P	CREDIT
		VAC	3	1	0	4

**Preamble:** This course aims to develop the skills for methods of various transformation and analysis of image enhancement, image reconstruction, image compression, image segmentation and image representation.

**Prerequisite:** ECT286 Introduction to Digital Signal Processing

**Course Outcomes:** After the completion of the course the student will be able to

CO 1	Analyze the various concepts and restoration techniques for image processing
CO 2	Differentiate and interpret the various image enhancement techniques
CO 3	Illustrate image segmentation algorithm
CO 4	Analyse basic image compression techniques

**Mapping of course outcomes with program outcomes**

	PO 1	PO 2	PO 3	PO 4	PO 5	PO 6	PO 7	PO 8	PO 9	PO 10	PO 11	PO 12
CO 1	3	3	2		1							2
CO 2	3	3	2		1							2
CO 3	3	3	3		1							2
CO 4	3	3	3		1							2

**Assessment Pattern**

Bloom's Category		Continuous Assessment Tests		End Semester Examination
		1	2	
Remember	K1	10	10	10
Understand	K2	20	20	20
Apply	K3	20	20	70
Analyse	K4			
Evaluate				
Create				

**Mark distribution**

Total Marks	CIE	ESE	ESE Duration
150	50	100	3 hours

## Continuous Internal Evaluation Pattern:

Attendance	: 10 marks
Continuous Assessment Test (2 numbers)	: 25 marks
Assignment/Quiz/Course project	: 15 marks

**End Semester Examination Pattern:** There will be two parts; Part A and Part B. Part A contain 10 questions with 2 questions from each module, having 3 marks for each question. Students should answer all questions. Part B contains 2 questions from each module of which student should answer any one. Each question can have maximum 2 sub-divisions and carry 14 marks.

## Course Level Assessment Questions

**Course Outcome 1 (CO1):** Analyze the various concepts and restoration techniques for image processing

1. For the given image check whether pixel P and Q have 8 connectivity .
2. Find filtered image using median filter.
3. Explain Weiner filtering.

**Course Outcome 2 (CO2):** Differentiate and interpret the various image enhancement techniques

1. Classify different image enhancement process. Differentiate between spatial domain and frequency domain techniques of image enhancement.
2. What is histogram equalisation? Briefly discuss the underlying logic behind histogram equalisation.
3. Apply mean and median filters over a given image.

**Course Outcome 3 (CO3):** Illustrate image segmentation algorithm

1. Name two basic approaches of image segmentation and mention their differences.
2. How can you decide optimal thresholds when the image contains a background and several foreground objects? Write down a corresponding algorithm.
3. Write down the region growing algorithm. What are its advantages and disadvantages.

**Course Outcome 4 (CO4):** Analyze basic image compression techniques

1. What do you mean by compression ratio? Do you consider that lower compression ratio ensures better images upon reproduction?
2. How can achievable compression ratio to be determined from image histogram?
3. Mention the steps of lossy and lossless JPEG compression

**Module 1**

Digital Image Fundamentals-Elements of visual perception, image sensing and acquisition, image sampling and quantization, basic relationships between pixels – neighborhood, adjacency, connectivity, distance measures.

Brightness, contrast, hue, saturation, mach band effect, Colour image fundamentals-RGB, CMY, HIS models, 2D sampling, quantization.

**Module 2**

Image Enhancement: Spatial domain methods: point processing-intensity transformations, histogram processing, image subtraction, image averaging, geometric transformation  
Sharpening filters – first and second derivative, two-dimensional DFT and its inverse, frequency domain filters – low-pass and high-pass.

**Module 3**

Image segmentation: Classification of Image segmentation techniques, region approach, clustering techniques

Classification of edges, edge detection, Hough transform, active contour

Thresholding – global and adaptive

**Module 4**

Image restoration: Restoration Models, Linear Filtering Techniques: Inverse and Wiener, Non linear filtering: Mean, Median, Max and Min filters

Noise Models: Gaussian, Uniform, Additive, Impulse

Image restoration applications

**Module 5**

Image Compression- Need for compression, redundancy, classification of image compression schemes, Huffman coding, arithmetic coding

Redundancy–inter-pixel and psycho-visual; Lossless compression – predictive, entropy; Lossy compression- predictive and transform coding – DST, DCT, wavelet transform (basics only); Still image compression standards – JPEG and JPEG-2000

**Text Books**

1. Farid Gonzalez Rafel C, Digital Image Processing, Pearson Education, 2009
2. S Jayaraman, S Esakkirajan, T Veerakumar, Digital image processing ,Tata Mc Graw Hill, 2015

**Reference Books**

1. Jain Anil K, Fundamentals of digital image processing, PHI 1988
2. Kenneth R Castleman, Digital image processing, Pearson Education, 2/e, 2003
3. Pratt William K, Digital Image Processing, John Wiley,4/e, 2007.

## Course Contents and Lecture Schedule

No.	Topic	No. of Lectures
<b>1</b>	<b>Introduction</b>	
1.1	Digital Image Fundamentals-Elements of visual perception, image sensing and acquisition	1
1.2	Image sampling and quantization, basic relationships between pixels – neighbourhood, adjacency, connectivity, distance measures	2
1.3	Brightness, contrast, hue, saturation, mach band effect	3
1.4	Impulse response and its relation with transfer function of linear systems. Block diagram representation and reduction methods	3
1.5	2D sampling, quantization	1
<b>2</b>	<b>Image Enhancement</b>	
2.1	Spatial domain methods: point processing-intensity transformations	1
2.2	Histogram processing, image subtraction, image averaging, geometric transformations	3
2.3	Sharpening filters	2
2.4	First and second derivative, two-dimensional DFT and its inverse, frequency domain filters – low-pass and high-pass	1
<b>3</b>	<b>Image segmentation:</b>	
3.1	Spatial domain methods: point processing-intensity transformations	3
3.2	Classification of Image segmentation techniques, region approach, clustering techniques	2
3.3	Classification of edges, edge detection, Hough transform, active contour	2
3.4	Thresholding – global and adaptive	3
<b>4</b>	<b>Image Restoration:</b>	
4.1	Restoration Models -Noise Models : Gaussian , Uniform, Additive, Impulse and Erlang	2
4.2	Linear Filtering Techniques : Inverse and Wiener	3
4.3	Non linear filtering: Mean, Median, Max and Min filters	2
4.3	Applications of Image restoration	1
<b>5</b>	<b>Image Compression-</b>	
5.1	Need for compression, redundancy,	1

5.2	classification of image compression schemes, Huffman coding, arithmetic coding	2
5.3	Redundancy–inter-pixel and psycho-visual;	1
5.4	Lossless compression – predictive, entropy;	2
5.5	Lossy compression- predictive and transform coding DST, wavelet	2
5.6	Still image compression standards – JPEG and JPEG-2000	1

APJ ABDUL KALAM  
TECHNOLOGICAL  
UNIVERSITY

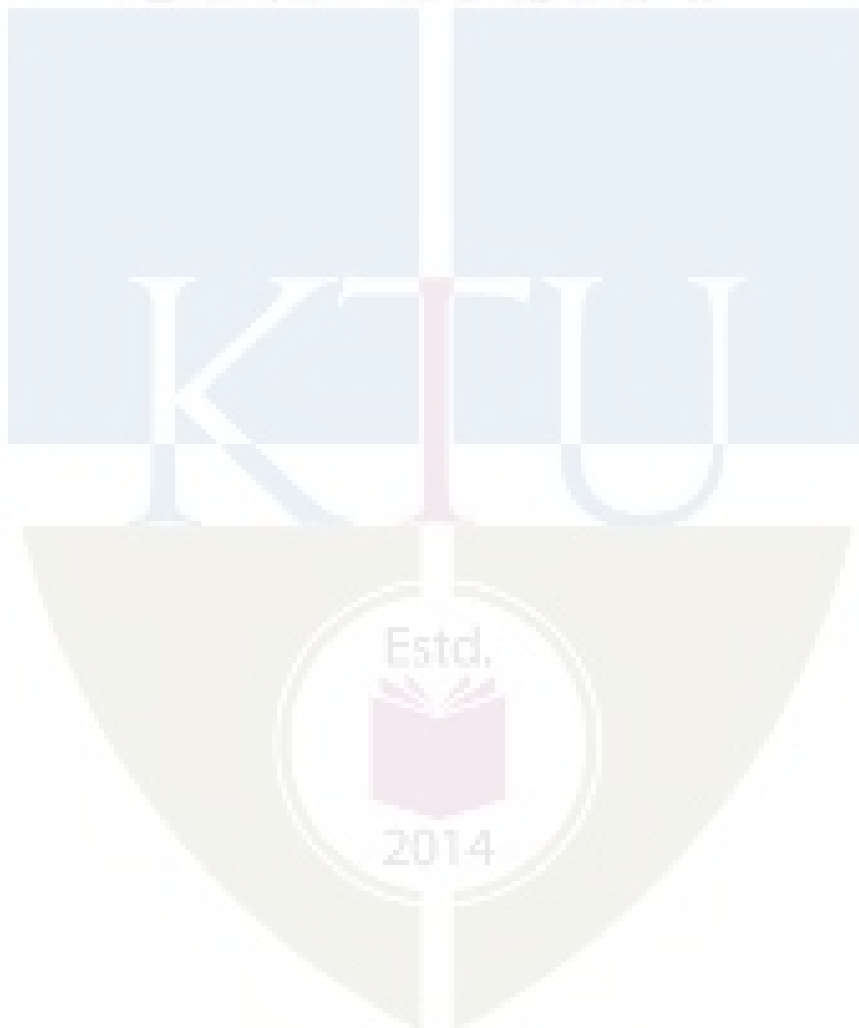

The following simulation assignments can be done with Python/MATLAB/SCILAB/LabVIEW

### 1 Simple Image Processing Operations

- Read a gray scale image like *Lena* or *ascent*, available in the platform.
- Print the pixel values in  $[0, 255]$  and appreciate them.
- Show the image.
- Observe the histogram of this image and appreciate it.
- Apply a nonlinear transformation such as logarithm of pixels and observe the changes in intensity due to compression/expansion of pixel values.
- Plot the histogram of the transformed image over the previous histogram and appreciate the changes.
- Apply cropping to the image and observe the cropped values.
- transform the gray scale image to a binary image by setting all values above 127 to 255 and those below to 0 and observe the binary image.
- Read in a color image and separate the RGB channels and observe them in color separately.
- Apply the logarithmic transformation to all channels separately and combined the transformed images to form a new color image and compare with the original color image.

### 2 Image Compression with Singular Value De-composition

- Read in a gray scale and read the pixel values ( $I$ ) into an array.
- Apply singular value decomposition of this array as

$$\tilde{I} = \sum_{i=0}^Q \lambda_i U_i V_i^T$$

- Plot the eigen values and appreciate their fading in magnitude.
- Take the first  $Q = 10$  eigen values and make the rest zero.
- Now reconstruct a compressed image for  $Q = 10$ ,  $Q = 100$  and appreciate the compression ratios.
- Take a picture of your face and crop it into suitable dimensions and apply the previous steps and observe the compression by SVD.

### 3 Filters for Noise Removal

- Read in a gray scale image and observe it.
- Add AWGN to it of known variance.
- Construct mean and median filters and apply on the noisy images and observe the removal of noise.
- Quantify the noise removal by computing the SNR and PSNR values as

$$SNR = 10 \log_{10} \left[ \frac{\sum_{n_1} \sum_{n_2} r^2[n_1, n_2]}{\sum_{n_1} \sum_{n_2} [r^2[n_1, n_2] - t^2[n_1, n_2]]} \right]$$

The peak value of the SNR is expressed as

$$PSNR = 10 \log_{10} \left[ \frac{\max(r^2[n_1, n_2])}{\frac{1}{N_1 N_2} \sum_{n_1} \sum_{n_2} [r^2[n_1, n_2] - t^2[n_1, n_2]]} \right]$$

where  $r$  denotes the reference image and  $t$  denotes the test image.

- Plot these values against different noise variances for mean and median filters and appreciate.

### 4 Gaussian Filter for Smoothing

- Read in a gray scale image and observe it.
- Realize a Gaussian kernel with impulse response

$$h = \frac{1}{273} \begin{bmatrix} 1 & 4 & 7 & 4 & 1 \\ 4 & 16 & 26 & 16 & 4 \\ 7 & 26 & 41 & 26 & 7 \\ 4 & 16 & 26 & 16 & 4 \\ 1 & 4 & 7 & 4 & 1 \end{bmatrix}$$

- Perform the two dimensional convolution and observe the smoothing, Also observe the blurring.
- Make the image noisy and repeat the procedure.
- Assess the visual quality of the image after Gaussian smoothing by computing the structural similarity index as

$$SSIM(\mathbf{x}, \mathbf{y}) = \frac{(2\mu_x \mu_y + C_1)(2\sigma_{xy} + C_2)}{(2\mu_x^2 + 2\mu_y^2 + C_1)(2\sigma_x^2 + 2\sigma_y^2 + C_2)}$$

The parameters  $\mu_x$  and  $\mu_y$  are the means and  $\sigma_x^2$  and  $\sigma_y^2$  are the variances of  $\mathbf{x}$  and  $\mathbf{y}$  respectively.  $\sigma_{xy}^2$  is the covariance between  $\mathbf{x}$  and  $\mathbf{y}$ .  $C_1$  and  $C_2$  are non-zero constants included to avoid unstable results when  $\sigma_x^2 + \sigma_y^2$  or  $\mu_x^2 + \mu_y^2$  is very close to zero.

- One may take  $\mathbf{x}$  as the input image and  $\mathbf{y}$  as the filtered image and appreciate the performance of the filter.

## 5 Edge Detection Filters

- Read in a grayscale image.
- Construct a Laplacian filter with kernel

$$\begin{bmatrix} 0 & -1 & 0 \\ -1 & 4 & -1 \\ 0 & -1 & 0 \end{bmatrix}$$

- Apply Laplacian filter to the image and observe the edges.
- Test the invulnerability of edge detection to noise. Add noise to the signal of known variance and extract edges.
- Compute the crispness of the edges ( $\kappa$ ) with

$$\kappa = \frac{1}{N_1 N_2} \sum_{n_1} \sum_{n_2} \frac{|\sigma_{l[n_1, n_2]_{test}}^2 - \sigma_{l[n_1, n_2]_{ref}}^2|}{\sigma_{l[n_1, n_2]_{ref}}^2 \mu_{l[n_1, n_2]_{ref}}}$$

where the reference image is the output of filter without noise and the test image is the one with noise.

- Plot  $\kappa$  for different noise variances.
- Use the Gaussian kernel in Sec. 4 to perform two dimension convolution on the image.
- Perform Laplacian filtering on the resultant image to perform Laplacian of Gaussian (LoG) filtering. Observe the edges detected.
- Compute  $\kappa$  for different noise variances and compare the plots with those of Laplacian and understand the noise invulnerability of LoG filter.

## 6 Image Compression with DCT

- Read in a gray scale image.
- Apply type-II DCT and observe the coefficient.
- Make DCT coefficients that are less than 20% of the maximum equal to zero.
- Take inverse DCT and observe the image. Compute the compression ratio.
- Repeat for 30%, 40% and 50% values and observe the compressed image and the compression ratios.



APJ ABDUL KALAM  
TECHNOLOGICAL  
UNIVERSITY

**SEMESTER V**

**HONOURS**



ECT393	FPGA BASED SYSTEM DESIGN	CATEGORY	L	T	P	CREDIT
		VAC	3	1	0	4

**Preamble:** This course aims to develop the skill of FPGA based system design.

**Prerequisite:** ECT203 Logic Circuit Design

**Course Outcomes:** After the completion of the course the student will be able to

CO 1	Design simple digital systems with programmable logic devices
CO 2	Analyze the architecture of FPGA
CO 3	Analyze the design considerations of FPGA
CO4	Design simple combinational and sequential circuits using FPGA

**Mapping of course outcomes with program outcomes**

	PO 1	PO 2	PO 3	PO 4	PO 5	PO 6	PO 7	PO 8	PO 9	PO 10	PO 11	PO 12
CO 1	3	3			2							2
CO 2	3	3			2							2
CO 3	3	3			2							2
CO 4	3	3			2							2

**Assessment Pattern**

Bloom's Category		Continuous Assessment Tests		End Semester Examination
		1	2	
Remember	K1	10	10	10
Understand	K2	30	30	60
Apply	K3	10	10	30
Analyze	K4			
Evaluate				
Create				

**Mark distribution**

Total Marks	CIE	ESE	ESE Duration
150	50	100	3 hours

**Continuous Internal Evaluation Pattern:**

Attendance : 10marks  
 Continuous Assessment Test(2numbers) : 25marks  
 Assignment/Quiz/Course project : 15marks

**End Semester Examination Pattern:** There will be two parts; Part A and Part B. Part A contain 10 questions with 2 questions from each module, having 3 marks for each question. Students should answer all questions. Part B contains 2 questions from each module of which student should answer any one. Each question can have maximum 2 sub-divisions and carry 14 marks.

### Course Level Assessment Questions

**Course Outcome 1 (CO1): Design simple digital systems with programmable logic devices.**

1. Design a decade counter using Verilog.
2. Implement a full adder using ROM

**Course Outcome 2 (CO2): Analyze the architecture of FPGA**

1. Compare coarse and fine grained FPGA.
2. Explain the architecture of logic block of FPGA

**Course Outcome 3 (CO3): Analyze the design considerations of FPGA**

1. What are the vendor specific issues in FPGA design.
2. Analyze Timing and Power dissipation in a typical FPGA.

**Course Outcome 4 (CO4): Design simple combinational and sequential circuits using FPGA.**

1. Implement a counter in Xilinx Virtex.
2. Explain how sequential circuit can be mapped into Xilinx Virtex LUT.

Estd.



2014

**SYLLABUS****Module 1:**

**Introduction:** Digital system design options and tradeoffs, Design methodology and technology overview, High Level System Architecture and Specification: Behavioral modelling and simulation, Hardware description languages (emphasis on Verilog), combinational and sequential design, state machine design, synthesis issues, test benches.

**Module 2:**

**Programmable logic Devices:** ROM, PLA, PAL, CPLD, FPGA Features, Limitations, Architectures and Programming. Implementation of MSI circuits using Programmable logic Devices.

**Module 3:**

**FPGA architecture:** FPGA Architectural options, granularity of function and wiring resources, coarse V/s fine grained, vendor specific issues (emphasis on Xilinx and Altera), Logic block architecture: FPGA logic cells, timing models, power dissipation I/O block architecture: Input and Output cell characteristics, clock input, Timing, Power dissipation.

**Module 4:**

**Placement and Routing:** Programmable interconnect - Partitioning and Placement, Routing resources, delays; Applications -Embedded system design using FPGAs, DSP using FPGAs.

**Module 5:**

**Commercial FPGAs:** Xilinx, Altera, Actel (Different series description only), Case study Xilinx Virtex: implementation of simple combinational and sequential circuits.

**Text Books**

1. FPGA-Based System Design Wayne Wolf, Verlag: Prentice Hall
2. Modern VLSI Design: System-on-Chip Design (3rd Edition) Wayne Wolf, Verlag

**Reference Books**

1. Field Programmable Gate Array Technology - S. Trimberger, Edr, 1994, Kluwer Academic
2. Digital Design Using Field Programmable Gate Array, P.K. Chan & S. Mourad, 1994, Prentice Hall
3. Field programmable gate array, S. Brown, R.J. Francis, J. Rose, Z.G. Vranesic, 2007, BS

**Course Contents and Lecture Schedule**

No	Topic	No. of Lectures
<b>1</b>	<b>Introduction</b>	
1.1	Digital system design options and tradeoffs	1
1.2	Design methodology and technology overview	2
1.3	High Level System Architecture and Specification: Behavioral modelling and simulation	2
1.4	Hardware description languages, combinational and sequential design	2
1.5	State machine design, synthesis issues, test benches.	2
<b>2</b>	<b>Programmable logic Devices</b>	
2.1	ROM, PLA, PAL, CPLD	3
2.2	FPGA Features, Limitations, Architectures and Programming.	2
2.3	Implementation of MSI circuits using Programmable logic Devices.	3
<b>3</b>	<b>FPGA architecture</b>	
3.1	FPGA Architectural options	1
3.2	Granularity of function and wiring resources, coarse V/s fine grained, vendor specific issues (emphasis on Xilinx and Altera)	3
3.3	Logic block architecture: FPGA logic cells, timing models, power dissipation	3
3.4	I/O block architecture: Input and Output cell characteristics, clock input, Timing, Power dissipation.	3
<b>4</b>	<b>Placement and Routing</b>	
4.1	Programmable interconnect - Partitioning and Placement	3
4.2	Routing resources, delays	3
4.3	Applications -Embedded system design using FPGAs, DSP using FPGAs	3
<b>5</b>	<b>Commercial FPGAs</b>	
5.1	Xilinx, Altera, Actel (Different series description only)	2
5.2	Case study Xilinx Virtex	4
5.3	Implementation of simple combinational and sequential circuits	3

**Model Question paper****APJ ABDUL KALAM TECHNOLOGICAL UNIVERSITY**

FIFTH SEMESTER B.TECH DEGREE EXAMINATION, (Model Question Paper)

Course Code: ECT393

Program: Electronics and Communication Engineering

Course Name: FPGA Based System Design

Max.Marks: 100

Duration: 3Hours

**PART A**

Answer ALL Questions. Each Carries 3 mark.

1.	What are the synthesis issues in FPGA design.	K2
2	Describe FPGA design methodology.	K2
3	Differentiate PLA with PAL	K2
4	What are the limitations of FPGA.	K2
5	Compare coarse and fine grained FPGA architecture.	K2
6	What are the timing models in logic block architecture.	K2
7	List the applications of FPGA.	K2
8	Describe routing resources in FPGA routing.	K2
9	Describe how a combnational circuit can be mapped into Xilinx Virtex LUT.	K2
10	List different commercially available FPGAs.	K2

**PART – B**

Answer one question from each module; each question carries 14 marks.

**Module – I**

11. a)	Design a full adder using Verilog.	7	CO1	K3
11. b)	Explain behavioral modeling and simulation with an example.	7	CO1	K2
<b>OR</b>				
12.a)	What is FSM? How it is used for FPGA.	7	CO1	K2
12.b)	Explain the purpose of test bench and how it is written in a HDL.	7	CO1	K2

**Module – II**

13 a)	Design the function $F=XYZ'+Y'Z+XY'$ using PLA	8	CO2	K3
13 b)	Compare CPLD with FPGA	6	CO2	K2
<b>OR</b>				
14 a)	Implement the following Boolean function using PAL: $F(w, x, y, z) = \sum m(0, 2, 4, 10, 11, 12, 14, 15)$	8	CO2	K3
14 b)	Draw the structure of PAL and explain it.	6	CO2	K2

**Module – III**

15 a)	Draw and explain I/O block architecture of FPGA.	7	CO2	K2
15 b)	Draw and explain coarse grained FPGA architecture.	7	CO2	K2
<b>OR</b>				
16 a)	Explain timing and power dissipation in Logic block and I/O block.	7	CO2	K2
16 b)	Draw and explain fine grained FPGA architecture.	7	CO2	K2

**Module – IV**

17 a)	Explain partitioning and placement processes in FPGA	8	CO4	K2
17 b)	Explain embedded system design using FPGAs	6	CO4	K2
<b>OR</b>				
18 a)	Explain the delays associated with placement and routing	7	CO4	K2
18 b)	Explain DSP design using FPGAs	7	CO4	K2

**Module – V**

19 a)	With neat diagram explain the architecture of Xilinx Virtex IOB.	7	CO3	K2
19 b)	Design a four bit up counter with parallel load feature using Xilinx Virtex.	7	CO3	K3
<b>OR</b>				
20 a)	Explain the mapping of combinational and sequential circuits using LUTs.	5	CO3	K3
20 b)	Explain the architecture of Xilinx Virtex CLB	9	CO3	K2

ECT395	DETECTION AND ESTIMATION THEORY	CATEGORY	L	T	P	CREDIT
		VAC	3	1	0	4

**Preamble:** This course aims to impart the fundamentals of detection and estimation theory in engineering applications

**Prerequisite:** MAT 101 Linear Algebra and Calculus

MAT 204 Probability, Random Process, and Numerical Methods

ECT 204 Signals and Systems

**Course Outcomes:** After the completion of the course the student will be able to

<b>CO1 K2</b>	Understand the fundamentals of statistical detection and estimation principles used in various engineering problems.
<b>CO2 K3</b>	Apply various types of statistical decision rules in engineering applications.
<b>CO3 K3</b>	Apply different types of estimation algorithms in engineering applications.

**Mapping of course outcomes with program outcomes**

	PO1	PO2	PO3	PO4	PO5	PO6	PO7	PO8	PO9	PO10	PO11	PO12
<b>CO 1</b>	3	3										2
<b>CO 2</b>	3	3										2
<b>CO 3</b>	3	3										2

**Assessment Pattern**

Bloom's Category	Continuous Assessment Tests		End Semester Examination
	1	2	
Remember			
Understand	K2	30	30
Apply	K3	20	20
Analyse			
Evaluate			
Create			

**Mark distribution**

Total Marks	CIE	ESE	ESE Duration
150	50	100	3 hours



**Continuous Internal Evaluation Pattern:**

Attendance	: 10 marks
Continuous Assessment Test (2 numbers)	: 25 marks
Assignment/Quiz/Course project	: 15 marks

**End Semester Examination Pattern:** There will be two parts; Part A and Part B. Part A contain 10 questions with 2 questions from each module, having 3 marks for each question. Students should answer all questions. Part B contains 2 questions from each module of which student should answer any one. Each question can have maximum 2 sub-divisions and carry 14 marks.

**Course Level Assessment Questions****Course Outcome 1 (CO1): Understand the fundamentals of statistical detection and estimation principles used in various engineering problems. (K2)**

1. Differentiate estimation and detection techniques.
2. Differentiate classical approach and bayesian approach in detection theory (or estimation).
3. Enumerate different applications which are using estimation and detection techniques.
4. Give the mathematical formulation of estimation and detection methods.
5. Draw receiver operating characteristics with all details
6. Give the significance of Bayes risk
7. How multiple hypothesis testing is done.
8. Give the significance of linear models in estimation and detection theory.
9. Significance of Cramer-Rao Lower Bound in estimation.
10. Differentiate MAP and ML methods in estimation (or detection).

**Course Outcome 2 (CO2): Apply various types of statistical decision rules in engineering applications. (K3)**

1. Describe Neyman-Pearson theorem (or Bayes risk or minimization of probability of error) and apply it to any binary hypothesis (eg. Signal in white Gaussian noise)
2. Derive/Obtain the matched filters for the detection of deterministic signals
3. Derive/Obtain the estimator-correlator for the detection of random signals

**Course Outcome 3 (CO3): Apply different types of estimation algorithms in engineering applications. (K3)**

1. Derive/Obtain the Minimum variance unbiased estimator (or best linear unbiased estimator) for any simple examples (eg. DC Signal in white Gaussian noise)
2. Derive/Obtain the Maximum likelihood estimator (or least squares estimator or minimum mean square error estimator) for any simple examples (eg. DC Signal in white Gaussian noise)
3. Using Bayesian approach, obtain an estimator for any simple examples.

**SYLLABUS**

**Module 1 : Introduction to Detection and Estimation Theory**

Fundamentals of detection theory, the mathematical detection problem. Fundamentals of estimation theory, the mathematical estimation problem. Review of Gaussian distribution. Application examples.

**Module 2 : Statistical Detection Theory I**

Hypothesis testing, classical approach, Neyman-Pearson theorem, likelihood ratio test, receiver operating characteristics, Bayesian approach, minimum probability of error, Bayes risk, multiple hypothesis testing.

**Module 3 : Statistical Detection Theory II**

Detection of deterministic signals, matched filters, detection of random signals, estimator-correlator, linear model, application examples.

**Module 4 : Statistical Estimation Theory I**

Minimum variance unbiased estimation, basics of Cramer-Rao Lower Bound, linear models, best linear unbiased estimation, application examples.

**Module 5 : Statistical Estimation Theory II**

Maximum likelihood estimation, least squares, Bayesian philosophy, minimum mean square error estimation, application examples.

**Text Books**

1. S.M. Kay, "Fundamentals of Statistical Signal Processing" Vol I: Estimation Theory, Pearson, 3/e, 2010.
2. S.M. Kay, "Fundamentals of Statistical Signal Processing" Vol II: Detection Theory, Pearson, 3/e, 2010.

**Reference Books**

1. H. L. Van Trees, "Detection, Estimation, and Modulation Theory", Vol. I, John Wiley & Sons, 1968
2. Monson H. Hayes, "Statistical Digital Signal Processing and Modelling" by, John Wiley & Sons, 2002.

## Course Contents and Lecture Schedule

No	Topic	No. of Lectures
<b>1</b>	<b>Introduction to Detection and Estimation Theory</b>	
1.1	Fundamentals of detection theory, review of probability and random variable	2
1.2	The mathematical detection problem	2
1.3	Fundamentals of estimation theory	1
1.4	The mathematical estimation problem	2
1.5	Review of Gaussian distribution. Application examples.	2
<b>2</b>	<b>Statistical Detection Theory I</b>	
2.1	Hypothesis testing	2
2.2	Classical approach, Neyman-Pearson theorem	2
2.3	Likelihood ratio test, Receiver operating characteristics	2
2.4	Bayesian approach, minimum probability of error, Bayes risk	2
2.5	Multiple hypothesis testing.	1
<b>3</b>	<b>Statistical Detection Theory II</b>	
3.1	Detection of deterministic signals	1
3.2	Matched filters	2
3.3	Detection of random signals	2
3.4	Estimator-correlator	2
3.5	Linear model, application examples.	2
<b>4</b>	<b>Statistical Estimation Theory I</b>	
4.1	Minimum variance unbiased estimation	2
4.2	Basics of Cramer-Rao Lower Bound	2
4.3	Linear models	2
4.4	Best linear unbiased estimation	2
4.5	Application examples	1
<b>5</b>	<b>Statistical Estimation Theory II</b>	
5.1	Maximum likelihood estimation	2
5.2	Least squares solution	2
5.3	Bayesian philosophy	2
5.4	Minimum mean square error estimation	2
5.5	Application examples	1

**Simulation Assignments (using MATLAB or Python)**

1. Generate and familiarize PDF and CDF of Normal distribution.
2. Generate DC level in White Gaussian Noise.
3. Simulate a Neyman-Pearson Detector.
4. Simulate a Maximum Likelihood Estimator.
5. Simulate a Best Linear Unbiased Estimator.

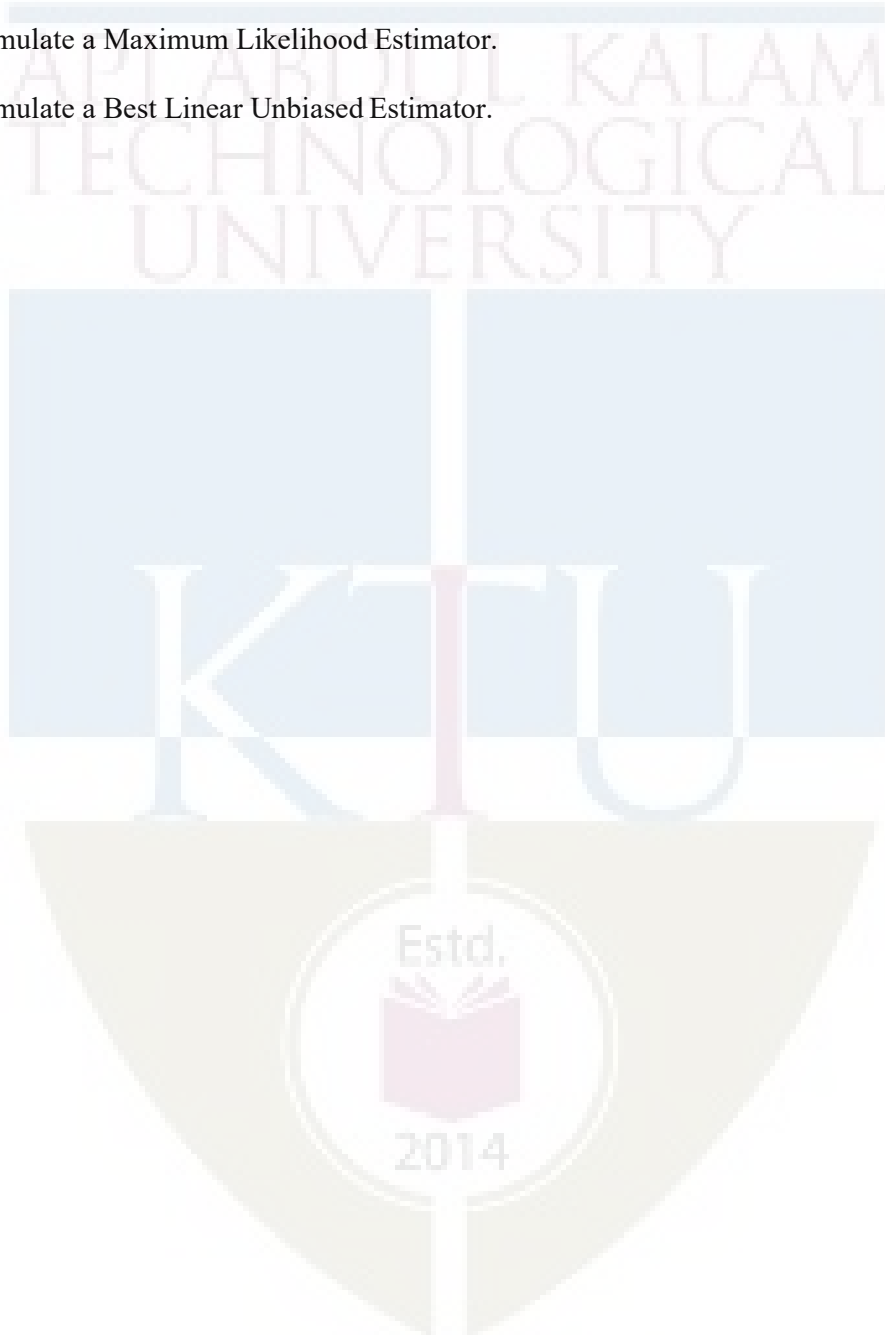

**MODEL QUESTION PAPER**

**APJ ABDUL KALAM TECHNOLOGICAL  
UNIVERSITY FIFTH SEMESTER B.TECH DEGREE  
EXAMINATION**

**ECT 395 - Detection and Estimation Theory**

Max. Marks: 100

Duration: 3 hrs

**PART A**

*(Answer **all** questions. Each question carries 3 marks each).*

1. Enumerate different applications which are using estimation and detection techniques. (3)
2. Differentiate estimation and detection techniques. (3)
3. Differentiate classical approach and bayesian approach in detection theory. (3)
4. Give the mathematical formulation of detection methods. (3)
5. Draw receiver operating characteristics with all details (3)
6. Give the significance of Bayes risk (3)
7. Give the significance of linear models in estimation theory. (3)
8. Significance of Cramer-Rao Lower Bound in estimation. (3)
9. What is Minimum Variance Unbiased Estimation? (3)
10. Differentiate MAP and ML methods in estimation. (3)

**PART B**

*(Answer any **one** question from each module. Each question carries 14 marks each.)*

Note:

(1) Notation  $x \sim N(\mu, \sigma^2)$  denotes  $x$  is normally distributed with mean  $\mu$  and variance  $\sigma^2$ .

(2) Also, bold small letters indicate vectors and bold capital letters indicate matrices.

11. Obtain the mathematical formulation of estimation method with an example. (14)

OR

- 12 Using radar system as an example, differentiate estimation and detection techniques. (14)

- 13 Design Neyman-Pearson detector for the unknown level  $A$  in White Gaussian Noise with variance  $\sigma^2$ . (14)

OR

- 14 Describe the Bayesian approaches in the design of detectors. (14)

- 15 Obtain Matched Filter detector for  $N$ -sample deterministic signal in noise,  $w[n] \sim N(0, \sigma_n^2)$  where  $w[n]$ 's are uncorrelated. (14)

OR

- 16 Describe estimator-correlator in the detection of random signals. (14)

- 17 Consider the multiple observations (14)

$$x[n] = A + w[n]; \quad n = 0, 1, \dots, N - 1$$

where  $w[n] \sim N(0, \sigma^2)$ . Determine CRLB for  $A$ ?

OR

- 18 Derive the Best Linear Unbiased Estimator for the multiple observations (14)

$$x[n] = A + w[n]; \quad n = 0, 1, \dots, N - 1$$

where  $A$  is an unknown level to be estimated and  $w[n]$  is White Noise with unspecified PDF and variance  $\sigma^2$ .

- 19 Derive the Maximum Likelihood Estimator for the multiple observations (14)

$$x[n] = A + w[n]; \quad n = 0, 1, \dots, N - 1$$

where  $A$  is an unknown level to be estimated and  $w[n]$  is White Gaussian Noise with known variance  $\sigma^2$ .

OR

20. Prove that the optimal estimator which minimizes the Bayesian Mean Square Error is the mean of the posterior PDF.

(14)

ECT397	COMPUTATIONAL TOOLS FOR SIGNAL PROCESSING	CATEGORY	L	T	P	CREDIT
		VAC	3	1	0	4

**Preamble:** This course aims to use the computational tools in signal processing to solve industry problems.

**Prerequisite:** ECL201 Scientific Computing Lab, ECT204 Signals and Systems, ECT303 Digital Signal Processing

**Course Outcomes:** After the completion of the course the student will be able to

CO 1	Compute posterior probability using pymc3 for practical applications
CO 2	Compute linear and logistic regression with pymc3
CO 3	Perform Bayesian analysis for practical applications.
CO 4	Implement Kalman filters
CO 5	Implement particle filters for practical applications

**Mapping of course outcomes with program outcomes**

	PO1	PO 2	PO 3	PO 4	PO 5	PO 6	PO 7	PO 8	PO 9	PO 10	PO 11	PO 12
CO 1	3	3			3							2
CO 2	3	3	2	3	3							2
CO 3	3	3	2	3	3	2						2
CO 4	3	3	2	3	3	2						2
CO 5	3	3	2	3	3	2						2

**Assessment Pattern**

Bloom's Category	Continuous Assessment Tests		End Semester Examination
	1	2	
Remember	10	10	20
Understand	30	30	60
Apply	10	10	20
Analyse			
Evaluate			
Create			

**Mark distribution**

Total Marks	CIE	ESE	ESE Duration
150	50	100	3 hours

**Continuous Internal Evaluation Pattern:**

Attendance : 10 marks  
 Continuous Assessment Test (2 numbers) : 25 marks  
 Assignment/Quiz/Course project : 15 marks

**End Semester Examination Pattern:** There will be two parts; Part A and Part B. Part A contain 10 questions with 2 questions from each module, having 3 marks for each question. Students should answer all questions. Part B contains 2 questions from each module of which student should answer any one. Each question can have maximum 2 sub-divisions and carry 14 marks.

### Course Level Assessment Questions

#### Course Outcome 1 (CO1): Computing posterior probability with pymc3

1. Write Python code to compute the posterior distribution of a 10X10 Gaussian random data set.
2. Write Python function to compute the autocorrelation of a 5X5 uniform random data.

#### Course Outcome 2 (CO2): Compute linear and logistic regression with pymc3

1. Write a python code to design a regression model by coding setosa =0, versicolor =1, and virginica = 2 in IRIS data set.?
2. Write a python code using pymc3 to estimate regression parameters using a simple linear model  $y \sim ax+b$ , where  $y$  is Normally distributed with mean  $ax+b$  and variance  $\sigma^2$

#### Course Outcome 3 (CO3): Perform Bayesian analysis for practical applications.

1. Write a python code using pymc3 to compute the bayes factor for the coin toss using a uniform prior  $\text{beta}(1,1)$  . Set  $p(\text{heads})=0.5$
2. Write a python code using pymc3 to implement a bayesian regression model with intercept1 and slope 3. Use posterior predictive checks to validate the model

#### Course Outcome 4 (CO4): Implement Kalman filters.

1. Write a python code to predict a random walk using discrete Bayes filter
2. Write a python code to track the movement of an accelerating aircraft using Kalman filter

#### Course Outcome 5 (CO5): Implement particle filters for practical applications

1. Write a python code using pymc3 to create a model that specifies the posterior probability of human sleeping pattern as a function of time using MCMC method.
2. Write a python code to track a robotic movement using Particle Filter

## SYLLABUS

### Module 1 Probabilistic Programming

Statistical Modelling using pymc3, Probability concepts, Bayes theorem, Bayesian Statistics and modelling, Modelling Coin flipping as Bayesian, Choosing the likelihood and prior, Posterior computation, Posterior predictive analysis, Posterior plots. Likelihood theory and Estimation

### Module 2 Modelling Linear and Logistic Regression

Modelling Linear Regression, Polynomial Regression, Multiple Linear Regression, Logistic Regression, Poisson Regression using pymc3



**Module 3 Bayesian Modelling**

Bayesian analysis using pymc3, Posterior predictive checks, Model specifications using pymc3, Examples of Bayesian Analytics. Bayes factor, Sequential Monte carlo to compute Bayes factors, Recursive state estimation, Modeling functions using pymc3, Covariance functions and kernels, Bayesian Regression Models

**Module 4 GH and Kalman Filter**

GH filter, Choosing G and H factors, Simple simulation models using GH filters, Discrete Bayes Filter for predicting the random movement, Recursive estimation and prediction, Effect of noisy environment. Kalman filter- updation using measurements and observations, Kalman Gain calculation and Prediction, Process noise and Measurement noise. Kalman Filter Equations implementation in python.

**Module 5 Particle Filter**

Multivariate Kalman Filter-Modelling and Designing, Effect of Nonlinearity, Nonlinear Filters, Smoothing, Adaptive Filtering. Markov concepts, Monte carlo integration, Basics of Markov chain Monte Carlo, Implementation using filterpy module. Particle Filter algorithm and Implementation.

**Textbooks and References**

1. “Bayesian Analysis with python”, Osvaldo Martin, PACKT Open Source Publishing
2. “Machine Learning: A Bayesian and Optimization Perspective”, Sergios Theodoridis, Academic Press.
3. <https://github.com/rlabbe/Kalman-and-Bayesian-Filters-in-Python>
4. <http://140.113.144.123/EnD108/Bayesian%20filtering-%20from%20Kalman%20filters%20to%20Particle%20filters%20and%20beyond.pdf>
5. “Ipython Interactive Computing and Visualization Cookbook”, Cyrille Rossant , PACKT Open Source Publishing
6. “Bayesian Signal Processing: Classical, Modern, and Particle Filtering Methods”, James V. Candy, Wiley-IEEE Press

**Course Contents and Lecture Schedule**

No	Topic	No. of Lectures
<b>1</b>	<b>Probabilistic Programming</b>	
1.1	Statistical Modelling using pymc3, Probability concepts	2
1.2	Bayes theorem, Bayesian Statistics and modelling	2
1.3	Modelling Coin flipping as Bayesian, Choosing the likelihood and prior, Posterior computation,	2
1.4	Posterior predictive analysis, Posterior plots. Likelihood theory and Estimation	3
<b>2</b>	<b>Modelling Linear and Logistic Regression</b>	
2.1	Modelling Linear Regression	2
2.2	Polynomial Regression, Multiple Linear Regression	2
2.3	Logistic Regression, Poisson Regression using pymc3	4

<b>3</b>	<b>Bayesian Modelling</b>	
3.1	Bayesian analysis using pymc3, Posterior predictive checks, Model specifications using pymc3, Examples of Bayesian Analytics.	3
3.1	Bayes factor, Sequential Monte carlo to compute Bayes factors, Recursive state estimation, Modeling functions using pymc3, Covariance functions and kernels.	3
3.3	Bayesian Regression Models.	2
<b>4</b>	<b>GH and Kalman Filter</b>	
4.1	GH filter, Choosing G and H factors, Simple simulation models using GH filters.	2
4.2	Discrete Bayes Filter for predicting the random movement, Recursive estimation and prediction, Effect of noisy environment.	2
4.3	Kalman filter- updation using measurements and observations, Kalman Gain calculation and Prediction, Process noise and Measurement noise. Kalman Filter Equations implementation in python.	4
<b>5</b>	<b>Particle Filter</b>	
5.1	Multivariate Kalman Filter - Modelling and Designing	2
5.2	Effect of Nonlinearity, Nonlinear Filters, Smoothing, Adaptive Filtering.	2
5.3	Markov concepts, Monte carlo integration, Basics of Markov chain Monte Carlo	2
5.4	Implementation using filterpy module. Particle Filter algorithm and Implementation.	4



1. Create a noisy measurement system. Design a g-h filter to filter out the noise and plot it. Write a code to filter 100 data points that starts at 5, has a derivative of 2, a noise scaling factor of 10, and uses  $g=0.2$  and  $h=0.02$ . Set your initial guess for  $x$  to be 100.
2. Design a filter to track the position of a train. Its position is expressed as its position on the track in relation to some fixed point which we say is 0 km. I.e., a position of 1 means that the train is 1 km away from the fixed point. Velocity is expressed as meters per second. Measurement of position is done once per second, and the error is  $\pm 500$  meters. The train is currently at 23 kilometers, moving at 15 m/s, accelerating at  $0.2 \text{ m/sec}^2$ . Plot the results.
3. Using Discrete Bayes Filter, predict the movement of a dog. The current position of the dog is 17 m. The epoch is 2 seconds long, and the dog is traveling at 15 m/s. Where will the dog be in two seconds?
4. Compute the statistics of a Gaussian function using filterpy() module
5. Design a Kalman filter to track the movement of a dog (parameters same as previous one) in a Noisy environment
6. Prove that the binomial and beta distributions are conjugate pairs with respect to the mean value.
7. Show that the conjugate prior of the multivariate Gaussian with respect to the precision matrix,  $Q$ , is a Wishart distribution.
8. Prove that if a probability distribution  $p$  satisfies the Markov condition, as implied by a BN, then  $p$  is given as the product of the conditional distributions given the values of the parents.
9. Suppose that  $n$  balls are thrown independently and uniformly at random into  $n$  bins.
  - (a) Find the conditional probability that bin 1 has one ball given that exactly one ball fell into the first three bins.
  - (b) Find the conditional expectation of the number of balls in bin 1 under the condition that bin 2 received no balls.
  - (c) Write an expression for the probability that bin 1 receives more balls than bin 2.

**Model Question Paper****A P J Abdul Kalam Technological University**

Fifth Semester B Tech Degree Examination

**Course: ECT 397 Computational Tools for Signal Processing****Time: 3 Hrs****Max. Marks:100****PART A***Answer All Questions*

- 1 State Bayes theorem and explain the significance of the terms (3)  $K_2$   
prior, likelihood and posterior.
- 2 Write Python code with pymc3 to realize a Bernoulli trial (3)  $K_3$   
with  $p(head) = 0.4$
- 3 Compare logistic and linear regression (3)  $K_2$
- 4 Explain the concept of Poisson regression and (3)  $K_2$   
logistic regression?
- 5 Write the significance of choosing conjugate priors in (3)  $K_2$   
Bayesian analysis
- 6 Explain Schwarz Criterion. (3)  $K_1$
- 7 Compare process noise and measurement noise in Kalman Filter. (3)  $K_2$
- 8 Write the algorithm for GH filter design (3)  $K_3$
- 9 Write a python code to compute relative error in the true value (3)  $K_3$   
of  $\pi$
- 10 Compare Nonlinear and Linear filters (3)  $K_2$

**PART B***Answer one question from each module. Each question carries 14 mark.***Module I**

11(A) Assume that you have a dataset with 100 data points of Gaussian distribution with a mean of 13 and standard deviation of 1.5. Using PyMC3, write Python code to compute: (8)  $K_3$

- The posterior distribution
- The prior distribution
- The posterior predictive distribution

11(B) Write a python code to find the Bayesian credible interval in the above question. How is it different from confidence interval. (6)  $K_3$

**OR**

12(A) Write a python code to evaluate the statistical correlation between variables in a  $5 \times 5$  Gaussian random dataset. (8)  $K_3$

12(B) Show that  $N(x|\mu, \Sigma)$  for known  $\Sigma$  is of an exponential form and that its conjugate prior is also Gaussian. (6)  $K_2$

**Module II**

13(A) Consider the linear model  $y = ax + b$  sampled from a probability distribution  $y \sim N(ax + b, \sigma^2)$ . Use pymc3, write a python code to estimate the parameters a,b and  $\sigma$ . (8)  $K_3$

13(B) Assume that  $x_n, n = 1, 2, \dots, N$ , are iid observations from a Gaussian distribution  $N(\mu, \sigma^2)$ . Obtain the MAP estimate of  $\mu$ , if the prior follows the exponential distribution  $p(\mu) = \lambda \exp(-\lambda\mu), \lambda > 0, \mu \geq 0$ . (6)  $K_2$

**OR**

14(A) Write a python code to generate random dataset using a noisy linear process with intercept 1, slope 2 and noise variance of 0.5. Simulate 100 data points and write a code to fit a linear regression to the data (8)  $K_3$

14(B) Write the steps involved in multiple linear regression technique (6)  $K_2$

**Module III**

- 15(A) Write a python code to estimate the mean and standard deviation of a randomly generated gaussian data using SMC method in pymc3 (8)  $K_3$
- 15(B) Explain how posterior predictive checks are used in validating a model using pymc3 (6)  $K_2$

**OR**

- 16(A) Consider the linear model  $y = \alpha + \beta * x$  sampled from a probability distribution  $y \sim N(\alpha + \beta * x, \epsilon)$ . Use pymc3, write a python code to estimate the best values of  $\alpha, \beta$  using Bayesian Linear Regression model. (8)  $K_3$
- 16(B) Explain the steps involved in calculating Bayes factor in pymc3 (6)  $K_2$

**Module IV**

- 17(A) Design an algorithm using Kalman filter to track a constant velocity aircraft in one dimension. (8)  $K_3$
- 17(B) Give a brief idea about recursive estimation technique. (6)  $K_2$

**OR**

- 18(A) Design an algorithm using Kalman filter to track an accelerating aircraft in one dimension. (8)  $K_3$
- 18(B) Explain the concept of Kalman filter gain factor. (6)  $K_2$

**Module V**

- 19(A) Describe the essential steps in the derivation of the Particle filter. (8)  $K_2$
- 19(B) Explain Sequential Importance sampling algorithm? (6)  $K_2$

**OR**

- 20(A) Explain Multivariate Kalman Filter algorithm. (8)  $K_2$
- 20(B) Explain different resampling algorithms used in designing particle filter (6)  $K_2$