

APJ ABDUL KALAM  
TECHNOLOGICAL  
UNIVERSITY

# SEMESTER II

KTU



**Discipline: CIVIL ENGINEERING**

**Stream : CE1**

CODE	COURSE NAME	CATEGORY	L	T	P	CREDIT
222TCE100	ADVANCED NUMERICAL METHODS	DISCIPLINE CORE 2	3	0	0	3

**Preamble:** For solving complex problems in mechanics and engineering, a post-graduate student must be well versed in numerical methods along with skills to apply them. This course equips the student with various numerical techniques that finds applications in civil engineering, across various streams (specialisations). Special focus is given to finite element method, explaining the relevance, versatility and fundamental concepts of this numerical tool.

**Course Outcomes:** After the completion of the course, the student will be able to

<b>CO 1</b>	Obtain the solution of simultaneous Linear system of equations
<b>CO 2</b>	Obtain the numerical solutions of ordinary differential equations
<b>CO 3</b>	Obtain the numerical solutions for solving boundary value problems of partial differential equations
<b>CO 4</b>	Describe the terminologies, applications or procedure of finite element method
<b>CO 5</b>	Describe or apply the concept of finite element method

#### Mapping of course outcomes with program outcomes

	PO 1	PO 2	PO 3	PO 4	PO 5	PO 6	PO 7
<b>CO 1</b>	3			3			
<b>CO 2</b>	3			3			
<b>CO 3</b>	3			3			
<b>CO 4</b>	1		2	2	2	2	
<b>CO 5</b>	3			2	2	2	

(1-Weak, 2-Medium, 3- strong)

#### Assessment Pattern

Bloom's Category	End Semester Examination
Apply	25
Analyse	25
Evaluate	5
Create	5

#### Mark distribution

Total Marks	CIE	ESE	ESE Duration
100	40	60	2.5 hours

**Continuous Internal Evaluation Pattern:** 40 marks

Preparing a review article based on peer reviewed original publications (Minimum 10 publications shall be referred) : 15 marks

Course based task/Seminar/Data collection and interpretation : 15 marks

Test paper, 1 no. : 10 marks

Test paper shall include minimum 80% of the syllabus.

**Note:** Enough opportunity to explore the practical examples from specialization should be given to the students. One assignment/course project should be based on the coding or use of packages

**End Semester Examination Pattern:** 60 marks

The end semester examination will be conducted by the University. There will be two parts; Part A and Part B. Part A will contain 5 numerical/short answer questions with 1 question from each module, having 5 marks for each question (such questions shall be useful in the testing of knowledge, skills, comprehension, application, analysis, synthesis, evaluation and understanding of the students). Students should answer all questions. Part B will contain 7 questions (such questions shall be useful in the testing of overall achievement and maturity of the students in a course, through long answer questions relating to theoretical/practical knowledge, derivations, problem solving and quantitative evaluation), with minimum one question from each module of which student should answer any five. Each question can carry 7 marks.



QP CODE:

Reg No.: \_\_\_\_\_

Name: \_\_\_\_\_

**APJ ABDUL KALAM TECHNOLOGICAL UNIVERSITY FIRST SEMESTER  
M.TECH. DEGREE EXAMINATION, MONTH & YEAR**

**Course Code: XXXXXX**

**ADVANCED NUMERICAL METHODS**

Max. Marks: 60

Duration: 2.5 hours

**PART A**

(Answer **ALL** questions; each question carries 5 marks)

1. Explain the procedure of solution of Tridiagonal systems
2. Explain single shooting method for solving Boundary value problems
3. Explain the parabolic and elliptic partial differential equations with examples
4. Explain any five practical applications of Finite element in the con
5. Explain Generalised coordinates and Natural coordinates in Finite Element analysis

**PART B**

(Answer **any FIVE** questions; each question carries 7 marks)

6. Solve the system of equations by Jacobi's iteration considering initial approximation as  $[0.5, -0.5, 0.5]^T$

$$4x_1 + x_2 + x_3 = 2$$

$$x_1 + 5x_2 + 2x_3 = -6$$

$$x_1 + 2x_2 + 3x_3 = -4$$

7. Solve  $y' = x^2 + y$  for  $y=0.1$ , given that  $y(0)=1$  considering  $h=0.05$  using (i) Eulers method and (ii) Runge Kutta method

8. Solve the equation  $uxx + uyy = 0$  for the square mesh with boundary value as shown in figure

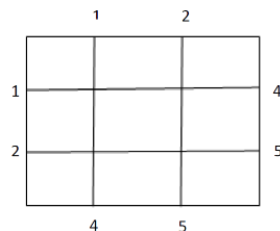

- CIVIL ENGINEERING-CE1
9. Solve  $\left(\frac{\partial u}{\partial t}\right) = \left(\frac{\partial^2 u}{\partial x^2}\right)$  subject to the conditions  $u(x,0) = \sin(\pi x)$  for  $0 \leq x \leq 1$   $u(0, t) = u(1, t) = 0$ . Perform the computations of two levels taking  $h=1/3$  and  $t=1/36$  using Crank Nicolson implicit scheme
10. Explain in detail the steps of finite element analysis
11. Explain forms of shape functions in finite element analysis
12. Explain the convergence criteria in finite element applications in detail

\*\*\*\*\*

## Syllabus

### Module 1

(7 hours)

Solutions of simultaneous Linear Systems of Equations- Solution of linear systems – Direct methods, Gauss-Jordan Method-Method of factorization- Solution of Tridiagonal Systems. Solution by matrix decomposition Iterative methods: Jacobi, Gauss-Siedel iteration for ordinary and sparse systems, Convergence of iterative solution schemes with examples.

### Module 2

(7 hours)

Solving Ordinary Differential Equations- The Elementary Theory of Initial-Value Problems -Euler's Method- Higher-Order Taylor Methods. Runge-Kutta Method- Introduction to solution methods for differential algebraic equations- Single shooting method for solving ODE-BVPs.

### Module 3

(7 hours)

Partial differential equations in two dimensions- Parabolic equations- Explicit finite difference method. Crank-Nicholson implicit method - Ellipse equations- Finite difference method-Problems with irregular boundaries.

### Module 4

(7 hours)

Introduction to Finite Element Method – Historical Background — Mathematical Modeling of field problems in Engineering — Governing Equations — Discrete and continuous models — Boundary, Initial and Eigen Value problems– Basic concepts of the Finite Element Method- Displacement approach-Concept of Stiffness Matrix and Boundary Condition-- General procedure of FEA

### Module 5

(7 hours)

Concept of Finite Element Method- Concept of Nodes, elements, Generalised coordinates and Natural coordinates in FEA. Shape functions – Polynomials - Lagrangian and Hermitian Interpolation — Compatibility - C0 and C1 elements - Convergence criteria - Conforming & nonconforming elements. Development of element matrices for one dimensional elements.

**Text Books**

1. Gupta, S.K. Numerical Methods for Engineers. Wiley Eastern, New Delhi, 1995.
2. Cook, R.D. Concepts and Applications of Finite Element Analysis, Wiley.

**Reference Books**

1. Gilbert Strang, Linear Algebra and its Applications (4th Ed.), Wellesley Cambridge Press 2009
2. Gourdin, A. and M Boumhrat. Applied Numerical Methods. Prentice Hall India, New Delhi 2000
3. Chopra S.C. and Canale R.P. Numerical Methods for Engineers, McGraw Hill 2006
4. Krishnamoorthy C S, *Finite Element Analysis- Theory and Programming*, Tata McGraw Hill, New Delhi., 1994
5. Rao, S.S. Finite Element Analysis, Elsevier Butterworth-Heinemann
6. Gerald and Wheatly, *Applied Numerical Analysis*, Pearson Education.
7. Rajasekharan S., *Numerical Methods in Science and Engineering*, S Chand & Company, 2003.
8. Bathe K J, *Finite Element Procedures in Engineering Analysis*, Prentice Hall, New Delhi. 1982
9. Chandrupatla T R and Belegundu A D, *Introduction to Finite Elements in Engineering*, Pearson Education, New Delhi 1998
10. Rajasekharan S, *Finite Element Analysis in Engineering Design*, Wheeler, New Delhi
11. Hutton D V, *Fundamentals of Finite Element Analysis*, Tata McGraw Hill Education Private Ltd, New Delhi

CODE	COURSE NAME	CATEGORY	L	T	P	CREDIT
222TCE001	ADVANCED CONCRETE TECHNOLOGY	PROGRAM CORE 3	3	0	0	3

**Preamble:** The course covers the properties of the ingredients of concrete and its influence on the performance of concrete. The course also focus to develop a strong understanding about the latest developments in the area of concrete technology with a clear knowledge about the fundamental mechanisms.

**Course Outcomes:** After the completion of the course on Advanced Concrete Technology the student will be able to

<b>CO 1</b>	Discuss the role of various ingredients in concrete with its properties
<b>CO 2</b>	Describe the various mix design procedures and tests on fresh and hardened properties
<b>CO 3</b>	Explain the various deterioration mechanisms in concrete
<b>CO 4</b>	Describe the various new methods and techniques used in concrete construction
<b>CO 5</b>	Explain the various quality tests for concrete

#### Mapping of course outcomes with program outcomes

	PO 1	PO 2	PO 3	PO 4	PO 5	PO 6	PO 7
<b>CO 1</b>	1		1				
<b>CO 2</b>	1		2	1			
<b>CO 3</b>	1		1				
<b>CO 4</b>			1	1			
<b>CO 5</b>	1		1				

(1- Weak, 2-Medium, 3- strong)

#### Assessment Pattern

Bloom's Category	End Semester Examination
Remember	15
Understand	20
Apply	20
Analyse	5
Evaluate	
Create	

**Mark distribution**

<b>Total Marks</b>	<b>CIE</b>	<b>ESE</b>	<b>ESE Duration</b>
100	40	60	2.5 hours

**Continuous Internal Evaluation Pattern:**

Preparing a review article based on peer reviewed original publications (minimum 10 publications shall be referred): 15 marks

Course based task/Seminar/Data collection and interpretation: 15 marks

Test paper, 1 no.: 10 marks

Test paper shall include minimum 80% of the syllabus.

**End Semester Examination Pattern:**

The end semester examination will be conducted by the respective College. There will be two parts; Part A and Part B. Part A will contain 5 numerical/short answer questions with 1 question from each module, having 5 marks for each question (such questions shall be useful in the testing of knowledge, skills, comprehension, application, analysis, synthesis, evaluation and understanding of the students).

Students should answer all questions. Part B will contain 7 questions (such questions shall be useful in the testing of overall achievement and maturity of the students in a course, through long answer questions relating to theoretical/practical knowledge, derivations, problem solving and quantitative evaluation), with minimum one question from each module of which students should answer any five. Each question can carry 7 marks.

**Note:** The marks obtained for the ESE for an elective course shall not exceed 20% over the average ESE mark % for the core courses. ESE marks awarded to a student for each elective course shall be normalized accordingly. For example, if the average end semester mark % for a core course is 40, then the maximum eligible mark % for an elective course is  $40 + 20 = 60\%$ .



**Model Question Paper****QP CODE:****Reg No.:** \_\_\_\_\_**Name:** \_\_\_\_\_**APJ ABDUL KALAM TECHNOLOGICAL UNIVERSITY SECOND SEMESTER  
M.TECH. DEGREE EXAMINATION,****MONTH & YEAR****Course Code: 222TCE001****222TCE001- ADVANCED CONCRETE TECHNOLOGY**

Time: 2.5 hrs.

Max. Marks: 60

**PART A**(Answer **ALL** questions; each question carries 5 marks)

- 1 Describe the characteristics of hydration products of cement and its influence in the properties of concrete.
- 2 Explain the influence of various factors affecting the workability of concrete on the rheological parameters.
- 3 Explain the methods to prevent corrosion of rebars in RCC.
- 4 Briefly describe the polymer concrete and its advantages and disadvantages.
- 5 How the temperature will affect the properties of concrete?

**PART B**(Answer **any FIVE** questions; each question carries 7 marks)

- 6 What are admixtures in concrete and its classification? Briefly explain superplasticizers and its mechanism of action.
  - 7 Mention the various steps involved in the high strength concrete mix design.
  - 8 What are the transport mechanisms in concrete and describe any one test for each of the mechanism.
  - 9 In a congested reinforced concrete work which type of concrete will you prefer and why? Explain its mix proportioning, properties, advantages and disadvantages.
  - 10 The condition assessment needs to be done in a concrete water tank. Which are the tests you recommend for assessing the quality and strength of concrete. Briefly explain the tests also.
  - 11 Why special concretes are needed and explain any three special concretes based on their application.
  - 12 What is durability of concrete? Describe the factors affecting the durability of concrete structures.
-

## Syllabus

### Module 1 - Materials for concrete

**Cement** - Production, composition, hydration chemistry, Structure of hydrated Cement, Solids in hydrated cement paste, Voids in hydrated cement paste and Water in hydrated cement paste. **Aggregates** - Geology of concrete aggregates, classification, testing of aggregates. **Chemical Admixtures** - Different Types, Influence on the properties of concrete

**Supplementary Cementitious Materials** - Different materials, Pozzolanic reaction, Influence on the properties of concrete **Fibres** - Types, Influence on the properties of concrete, Advantages and Disadvantages

### Module 2 - Concrete mix design and testing

**Concrete Mix design** - Methods of Concrete mix design, High performance and high strength concrete mixture proportioning. **Advanced topics in fresh concrete** - Rheology, pumping of concrete. **Advanced topics in hardened concrete** - Behavior under various loads, stress-strain relationships, Variability of concrete strength, creep and shrinkage.

### Module 3 - Durability problems of concrete

General, Durability related clauses in IS 456, Specification for concrete – prescriptive Vs performance, Chemical attack of concrete - sulphate attack, acid attack; Corrosion of steel rebars, Carbonation and chloride induced, Freeze-thaw resistance, alkali silica reaction, Effect of temperature on the properties of concrete, Durability Tests.

### Module 4 - Special Concretes

Self-compacting Concrete, Fibre reinforced Concrete, Light weight Concrete, Polymer Concrete, Heavy Weight concrete, Roller compacted concrete, Pervious/no fines concrete Coloured concrete, High strength concrete, Ultrahigh strength concrete, Bacterial concrete/Self-healing concrete, Self-cleaning Concrete

### Module 5 - Modern trends in concrete

Modern trends in concrete - manufacture, placing, transportation, compaction, finishing and curing, Non-destructive testing and quality control, White Topping, Emerging trends in replacement of conventional materials in concrete, Vacuum dewatering of concrete, under water concreting, Shotcreting, 3D printing

**Course plan**

<b>No</b>	<b>Topic</b>	<b>No. of Lectures</b>
<b>1</b>	<b>Materials for concrete</b>	
1.1	<b>Cement</b> – Production, composition, hydration chemistry, Structure of hydrated Cement, Solids in hydrated cement paste, Voids in hydrated cement paste and Water in hydrated cement paste.	3
1.2	<b>Aggregates</b> – Geology of concrete aggregates, classification, testing of aggregates	1
1.3	<b>Chemical Admixtures</b> – Different Types, Influence on the properties of concrete	1
1.4	<b>Supplementary Cementitious Materials:-</b> Different materials, Pozzolanic reaction, Influence on the properties of concrete	2
1.5	<b>Fibres</b> – Types, Influence on the properties of concrete, Advantages and Disadvantages	1
<b>2</b>	<b>Concrete mix design and testing</b>	
2.1	<b>Concrete Mix design</b> - Methods of Concrete mix design,	2
2.2	High performance and high strength concrete mixture proportioning	2
2.3	<b>Advanced topics in fresh concrete</b> – Rheology, pumping of concrete	2
2.4	<b>Advanced topics in hardened concrete</b> – Behavior under various loads, stress-strain relationships, Variability of concrete strength, creep and shrinkage.	2
<b>3</b>	<b>Durability problems of concrete</b>	
3.1	Durability problems of concrete– General	1
3.2	Chemical attack of concrete	2
3.3	Corrosion of steel rebars,	1
3.4	Freeze-thaw resistance, ASR attack, Carbonation	1
3.5	Durability design of concrete	1
3.5	Durability Tests	2
<b>4</b>	<b>Special Concretes</b>	
4.1	Self-compacting Concrete	1
4.2	Fibre reinforced Concrete	1
4.3	Light weight Concrete	1
4.4	Polymer Concrete	1
4.5	Heavy Weight concrete, Roller compacted concrete	1
4.6	Pervious/no fines concrete, Coloured concrete	1
4.7	High strength concrete, Ultra high strength concrete	1
4.8	Bacterial concrete/Self-healing concrete, Self-cleaning Concrete	1
<b>5</b>	<b>Modern trends in concrete</b>	

5.1	Modern trends in concrete - manufacture, placing, transportation	1
5.2	Modern trends in concrete –compaction, finishing and curing	1
5.3	Non destructive testing and quality control	2
5.4	White Topping	1
5.5	Emerging trends in replacement of conventional materials in concrete	1
5.6	Vacuum dewatering of concrete, Under water concreting, Shotcreting	1
5.7	Effect of temperature on the propertiesof concrete	1

### Reference Books

1. P. Kumar Mehta and Paulo J. M. Monteiro, Concrete: Microstructure, Properties and Materials, McGraw Hills, Newyork, 2013.
2. S. Mindess and J.F. Young, Concrete, Prentice-Hall, Englewood Cliffs, New Jersey, USA, 1981
3. A.M. Neville, Properties of Concrete, Pearson Education, Delhi, 2004.
4. A. M. Nevile, and J. J. Brookes, Concrete Technology, Pearson India Education Services Pvt. Ltd., India.
5. H.F.W. Taylor, *Cement Chemistry*, Thomas Telford Publ., London, 1997
6. *J.F. Young, S. Mindess, R.J. Gray & A. Bentur, The Science and Technology of Civil Engineering Materials, Prentice Hall, 1998.*
7. *P.-C. Aïtcin, High-Performance Concrete, E&FN Spon, London, 1998*
8. R. Rixom and N. Mailvaganam, *Chemical Admixtures for Concrete*, E&FN Spon, London, 1999.
9. *Indian Standard IS 10262-1982, Recommended guidelines for concrete mix design, Bureau of Indian Standards, New Delhi, 2019.*

<b>COURSE CODE</b>	<b>COURSE NAME</b>	<b>CATEGORY</b>	<b>L</b>	<b>T</b>	<b>P</b>	<b>CREDIT</b>
<b>222PCE100</b>	<b>MINI PROJECT</b>	<b>PROJECT</b>	<b>0</b>	<b>0</b>	<b>4</b>	<b>2</b>

Mini project can help to strengthen the understanding of student's fundamentals through application of theoretical concepts and to boost their skills and widen the horizon of their thinking. The ultimate aim of an engineering student is to resolve a problem by applying theoretical knowledge. Doing more projects increases problem solving skills.

The introduction of mini projects ensures preparedness of students to undertake dissertation. Students should identify a topic of interest in consultation with PG Programme Coordinator that should lead to their dissertation/research project. Demonstrate the novelty of the project through the results and outputs. The progress of the mini project is evaluated based on three reviews, two interim reviews and a final review. A report is required at the end of the semester.

Evaluation Committee - Programme Coordinator, One Senior Professor and Guide.

<b>Sl. No</b>	<b>Type of evaluations</b>	<b>Mark</b>	<b>Evaluation criteria</b>
1	Interim evaluation 1	20	
2	Interim evaluation 2	20	
3	Final evaluation by a Committee	35	Will be evaluating the level of completion and demonstration of functionality/ specifications, clarity of presentation, oral examination, work knowledge and involvement
4	Report	15	the committee will be evaluating for the technical content, adequacy of references, templates followed and permitted plagiarism level( not more than 25% )
5	Supervisor/Guide	10	
Total Marks		100	

CODE	COURSE NAME	CATEGORY	L	T	P	CREDIT
222LCE003	COMPUTATIONAL LAB	LABORATORY	0	0	2	1

**Preamble:** The course familiarizes the students with experimental and computational tools used in structural engineering and construction technology. The course imparts an ability to use these tools in research and solution of field problems.

**Course Outcomes:** After the completion of the course on Advanced Structural Engineering Lab, the student will be able to:

<b>CO 1</b>	Prepare computational models of structures
<b>CO 2</b>	Generate response of structures experimentally and/or using computational models
<b>CO 3</b>	Compute plot area and earthwork quantity using Total Station survey
<b>CO 4</b>	Analyse spatial data using GIS analysis tools
<b>CO 5</b>	Prepare lab reports

#### Mapping of course outcomes with program outcomes

	PO 1	PO 2	PO 3	PO 4	PO 5	PO 6	PO 7
<b>CO 1</b>	2		1				
<b>CO 2</b>	2		3	1	2		
<b>CO 3</b>	1		2		1		
<b>CO 4</b>	2		2	1	1		
<b>CO 5</b>		3	2				1

(1- Weak, 2-Medium, 3- strong)

#### Mark distribution

Total Marks	CIE	ESE	ESE Duration
100	100	-	-

#### Continuous Internal Evaluation Pattern:

The laboratory courses will be having only Continuous Internal Evaluation and carries 100 marks. Final assessment shall be done by two examiners; one examiner will be a senior faculty from the same department.

## **LIST OF EXPERIMENTS**

### **Computational modelling for Static Analysis**

Modelling and static Analysis (using Ansys or ABAQUS) of the following:

1. Modelling and analysis of Cantilever Beam
2. Modelling and analysis of Simply Supported Beam
3. Modelling and analysis of Portal Frame

### **Experimental and/or Computational modelling for Dynamic Analysis**

Dynamic testing and/or computational modelling (using Ansys or ABAQUS) of the following:

4. Free Vibration of Cantilever beam.
5. Dynamics of simply supported beam subjected to harmonic load.
6. Dynamics of a three storied building frame subjected to harmonic base motion
7. Dynamics of a vibration absorber
8. Dynamics of a four storied building frame with and without an open ground floor
9. Dynamics of a single span and two span beams

### **Total station survey**

10. Computation of area of a plot using Total Station survey
11. Contouring and plotting
12. Computation of earthwork from contour plot
13. Setting out of multi-level buildings
14. Setting out of a road with horizontal and vertical curves

### **GIS Functions**

15. Digitization and Geo-referencing
16. Spatial Analysis
17. Data Output – Different types

### **GIS Applications**

18. Environmental Applications
19. Transportation planning
20. Preparation of Maps and Layouts.

### **General Instructions to Faculty:**

Any 8 of the 20 experiments included in the list of experiments need to be performed mandatorily.

APJ ABDUL KALAM  
TECHNOLOGICAL  
UNIVERSITY

---

**SEMESTER II**

---

**PROGRAM ELECTIVE III**

---

Estd.



2014



CODE	COURSE NAME	CATEGORY	L	T	P	CREDIT
222ECE100	ANALYSIS AND DESIGN OF EARTHQUAKE RESISTANT STRUCTURES	PROGRAM ELECTIVE 3	3	0	0	3

**Preamble:** The course provides the basic principles of earthquake resistant design of structures. Students are introduced to the engineering aspects of earthquakes, their characterisation and effects. The course covers seismic design force computation, design and detailing as per Indian Standards. An introduction to seismic evaluation and retrofitting is also included.

**Course Outcomes:** After the completion of the course on Analysis and Design of Earthquake Resistant Structures the student will be able to

<b>CO 1</b>	Describe various engineering aspects of earthquakes, earthquake effects and earthquake resistant design.
<b>CO 2</b>	Apply IS code provisions for the analysis, design and detailing of earthquake resistant structures.
<b>CO 3</b>	Develop earthquake response spectrum.
<b>CO 4</b>	Perform response spectrum analysis of multi-storied frames.
<b>CO 5</b>	Analyse and design shear walls.
<b>CO 6</b>	Describe different strategies for seismic evaluation and seismic retrofitting.

#### Mapping of course outcomes with program outcomes

	PO 1	PO 2	PO 3	PO 4	PO 5	PO 6	PO 7
<b>CO 1</b>			1				
<b>CO 2</b>	1		3	2	2		
<b>CO 3</b>	2		2	1			
<b>CO 4</b>	1		2	2	2		
<b>CO 5</b>	1		2	2	2		
<b>CO 6</b>			1				

(1- Weak, 2-Medium, 3- strong)

#### Assessment Pattern

Bloom's Category	End Semester Examination
Remember	15
Understand	20
Apply	25
Analyse	
Evaluate	
Create	

**Mark distribution**

<b>Total Marks</b>	<b>CIE</b>	<b>ESE</b>	<b>ESE Duration</b>
100	40	60	2.5 hours

**Continuous Internal Evaluation Pattern:**

Preparing a review article based on peer reviewed original publications (minimum 10 publications shall be referred): 15 marks

Course based task/Seminar/Data collection and interpretation: 15 marks

Test paper, 1 no.: 10 marks

Test paper shall include minimum 80% of the syllabus.

**End Semester Examination Pattern:**

The end semester examination will be conducted by the respective College. There will be two parts; Part A and Part B. Part A will contain 5 numerical/short answer questions with 1 question from each module, having 5 marks for each question (such questions shall be useful in the testing of knowledge, skills, comprehension, application, analysis, synthesis, evaluation and understanding of the students).

Students should answer all questions. Part B will contain 7 questions (such questions shall be useful in the testing of overall achievement and maturity of the students in a course, through long answer questions relating to theoretical/practical knowledge, derivations, problem solving and quantitative evaluation), with minimum one question from each module of which students should answer any five. Each question can carry 7 marks. Total duration of the examination will be 150 minutes.

**Note:** The marks obtained for the ESE for an elective course shall not exceed 20% over the average ESE mark % for the core courses. ESE marks awarded to a student for each elective course shall be normalized accordingly. For example, if the average end semester mark % for a core course is 40, then the maximum eligible mark % for an elective course is  $40 + 20 = 60\%$ .

**QP CODE:**

**Reg No.:** \_\_\_\_\_

**Name:** \_\_\_\_\_

**APJ ABDUL KALAM TECHNOLOGICAL UNIVERSITY SECOND SEMESTER  
M.TECH. DEGREE EXAMINATION, MONTH & YEAR**

**Course Code: 222ECE000**

**ANALYSIS AND DESIGN OF EARTHQUAKE RESISTANT STRUCTURES**

Max. Marks: 60

Duration: 2.5 hours

**PART A**

(Answer **ALL** questions; each question carries 5 marks)

1. Distinguish between *magnitude* and *intensity* of earthquake.
2. Explain the philosophy of earthquake resistant design.
3. Can the exact value of maximum seismic response of a multi-degree of freedom be determined using response spectrum analysis? Explain.
4. Explain the significance of ductility in earthquake resistant design.
5. What do you mean by retrofitting of structures? Explain the retrofitting methods used for RC columns.

**PART B**

(Answer **any FIVE** questions; each question carries 7 marks)

6. Figure shows the plan of a four storied RC framed structure to be constructed in Bangalore. Height of each story is 3.0 m. Calculate the seismic forces at various floor levels.

*Data given:*

- Column section : 23×60 cm.
- Beam section : 23×55 cm.
- Slab Thickness : 13 cm.
- Thickness of brick wall around: 23 cm.
- Live load on floors : 4 kN/m<sup>2</sup>
- Live load on roof : 1.5 kN/m<sup>2</sup>
- Unit weight of concrete : 25 kN/m<sup>3</sup>
- Unit weight of brick wall : 20 kN/m<sup>3</sup>
- Frame type : SMRF
- Type of soil : Soft soil

Missing data may be suitably assumed.

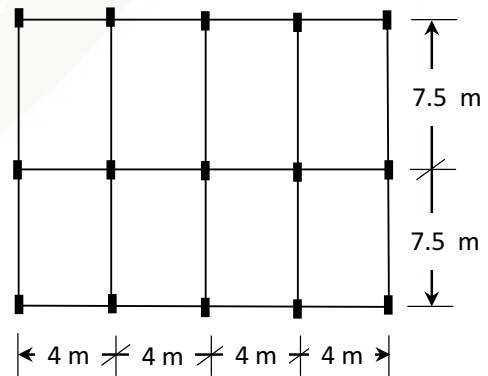

7. Explain the factors which ensure proper seismic behaviour of a building.
8. The natural frequencies (in rad/s) of the three storied shear building shown below are 6.57, 16.91 and 24.67. The mass normalized modal matrix is

$$\begin{bmatrix} 0.0034 & 0.0066 & 0.0067 \\ 0.0061 & 0.0038 & -0.0069 \\ 0.0080 & -0.0072 & 0.0031 \end{bmatrix}$$

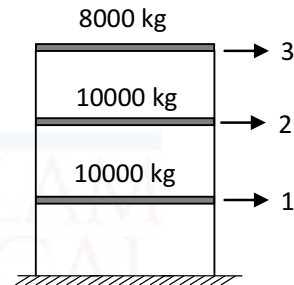

The damping may be assumed as 5% for all modes. Using response spectrum method calculate the base shear.

Assume that the building is to be constructed in Zone V and the foundation soil is Type I (hard soil). The frame may be assumed as SMRF. Take importance factor as 1.5. Use SRSS rule to combine the modal responses.

9. Explain how the ductility of RC members can be increased.
10. Plan of a single storey building having two shear walls in each direction is shown. The shear walls are 6 m long and 200 mm thick. Design shear force on the building is 120 kN in either direction. Determine the design lateral force in shear wall A using the torsion provisions of the IS code.

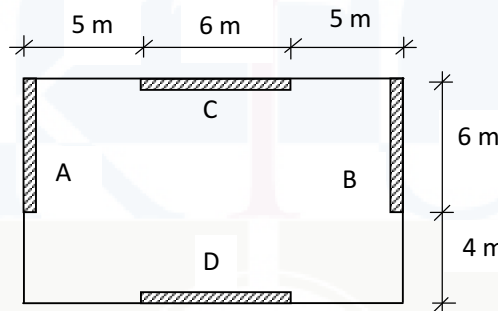

11. A slender shear wall of length 6 m and thickness 200 mm carries an axial load of 2700 kN. The wall is reinforced with 10# bars at 250 mm c/c in two layers. If M25 concrete and Fe415 steel are used, estimate the moment of resistance of the wall.
12. What is seismic evaluation? When is it required? Explain the different steps in seismic evaluation.

\*\*\*\*\*

## Syllabus

### Module 1

Introduction to earthquakes and earthquake engineering, Mechanism of earthquake, seismic waves, effects of earthquakes. Measurement of earthquakes, magnitude and intensity, seismographs. Strong motion characteristics, response spectrum, Fourier spectrum. Characteristics of response spectrum, Design spectrum, construction of tripartite response spectrum.

### Module 2

Effect of architectural features and structural irregularities. Damages of structures during past earthquakes, principles of earthquake resistant construction.

Philosophy of earthquake resistant design. Code provisions as per IS:1893 and IS:4326.

### Module 3

Design seismic force calculation in multi storied frames. Dynamic analysis, Introduction to response spectrum analysis – theoretical aspects, Modal combination rules.

Design seismic force calculation in multi storied frames using response spectrum method.

### Module 4

Ductility – Significance, Ductility factors. Ductile detailing considerations as per IS:13920. Design and detailing of structural members. Reinforcement detailing in joints.

### Module 5

Torsion – code provisions, Shear walls – design force calculation, Design of shear wall, Design and detailing for earthquake resistance – Discussion of code provisions in IS 13920.

Repair and rehabilitation. Seismic evaluation and vulnerability assessment – Methods, Disaster mitigation, Response reduction techniques, Base isolation.

### Course Plan

No	Topic	No. of Lectures
1	<b>Earthquakes and Response Spectrum (9)</b>	
1.1	Earthquakes, Mechanism, Elastic rebound theory. Seismic waves, Effects of earthquakes	3
1.2	Size of earthquake – magnitude & intensity, moment magnitude Measurement of earthquakes – seismographs	2
1.3	Strong motion characteristics, response spectrum, Fourier spectrum	2
1.4	Characteristics of response spectrum, design spectrum, construction of tripartite response spectrum	2
2	<b>Earthquake Effects and Philosophy of Earthquake Resistant</b>	

	<b>Construction (7)</b>	
2.1	Structural irregularities, Effect of architectural features, Damages during past earthquakes.	2
2.2	Seismo-resistant building architecture	1
2.3	Philosophy of earthquake resistant construction. Principle of earthquake resistant construction	2
2.4	Introduction of IS codes (1893 & 4326), Code provision	2
3	<b>Design Seismic Force Computation (8)</b>	
3.1	Seismic force computation using IS code provisions	2
3.2	Response spectrum analysis – theoretical aspects, Modal combination rules	2
3.3	Seismic force computation using Response spectrum method	2
3.4	Modal combination using ABS, SRSS & CQC rules	2
4	<b>Ductility Aspects and Ductile Detailing (7)</b>	
4.1	Ductility – significance in earthquake resistant design, Ductility factors.	2
4.2	Ductile detailing considerations as per IS:13920	2
4.3	Design & detailing of structural members & joints	3
5	<b>Torsion and Shear Walls (9)</b>	
5.1	Torsion – code provisions Design eccentricity computation	1
5.2	Shear walls – design force calculation. Design of shear wall.	3
5.3	Seismic evaluation – methods	2
5.4	Repair and rehabilitation – methods	2
5.5	Response reduction techniques, Base isolation	1

### Reference Books

1. Pankaj Agarwal and Manish Shrikhande, Earthquake Resistant Design of Structures, Prentice- Hall of India, New Delhi.
2. Anil K Chopra, Dynamics of Structures, Prentice- Hall of India, New Delhi.
3. S. K. Duggal-Earthquake Resistant Design of Structures-Oxford University Press-2007
4. T.K. Datta, Seismic Analysis of Structures, John Wiley & Sons (Asia) Pte Ltd.
5. IS: 1893-2016, Indian Standard criteria for Earthquake Resistant Design of Structures, Bureau of Indian Standards, New Delhi
6. IS: 4326-2013, Indian Standard code for practice for Earthquake Resistant Design and Construction of Buildings, Bureau of Indian Standards, New Delhi.
7. IS: 13920-2006, Indian Standard Ductile Detailing of RCC Structures subjected to seismic forces Code of practice, Bureau of Indian Standards, New Delhi

CODE	COURSE NAME	CATEGORY	L	T	P	CREDIT
222ECE001	ADVANCED METAL STRUCTURES	PROGRAM ELECTIVE 3	3	0	0	3

**Preamble:** The course focuses on design of steel and aluminium structures, in compliance with Indian and International codes. Analysis and design of bolted and welded connections, design of steel members under fire and blast loads, design of industrial structures, design of light gauge structures and design of aluminium structures are included.

**Course Outcomes:** After the completion of the course the student will be able to

<b>CO 1</b>	Design bolted and welded joints
<b>CO 2</b>	Design light gauge columns, beams, and tension members
<b>CO 3</b>	Design aluminium members under axial loads
<b>CO 4</b>	Design gantry girders

#### Mapping of course outcomes with program outcomes

	PO 1	PO 2	PO 3	PO 4	PO 5	PO 6	PO 7
<b>CO 1</b>			2	2	1		
<b>CO 2</b>			3	2	1		
<b>CO 3</b>			2	2	1		
<b>CO 4</b>			3	2	1		

(1-Weak, 2-Medium, 3- strong)

#### Assessment Pattern

Bloom's Category	End Semester Examination
Apply	30
Analyse	30
Evaluate	
Create	

#### Mark distribution

Total Marks	CIE	ESE	ESE Duration
100	40	60	2.5 hours

**Continuous Internal Evaluation:**

Preparing a review article based on peer reviewed original publications (minimum 10 publications shall be referred): 15 marks

Course based task/Seminar/Data collection and interpretation: 15 marks

Test paper, 1 no.: 10 marks

Test paper shall include minimum 80% of the syllabus.

**End Semester Examination Pattern:**

The end semester examination will be conducted by the respective College. There will be two parts; Part A and Part B. Part A will contain 5 numerical/short answer questions with 1 question from each module, having 5 marks for each question (such questions shall be useful in the testing of knowledge, skills, comprehension, application, analysis, synthesis, evaluation and understanding of the students). Students should answer all questions. Part B will contain 7 questions (such questions shall be useful in the testing of overall achievement and maturity of the students in a course, through long answer questions relating to theoretical/practical knowledge, derivations, problem solving and quantitative evaluation), with minimum one question from each module of which student should answer any five. Each question can carry 7 marks.

**Note:** The marks obtained for the ESE for an elective course shall not exceed 20% over the average ESE mark % for the core courses. ESE marks awarded to a student for each elective course shall be normalized accordingly. For example, if the average end semester mark % for a core course is 40, then the maximum eligible mark % for an elective course is  $40+20 = 60\%$





**Model Question Paper****QP CODE:****Reg No.:** \_\_\_\_\_**Name:** \_\_\_\_\_**APJ ABDUL KALAM TECHNOLOGICAL UNIVERSITY SECOND SEMESTER  
M.TECH. DEGREE EXAMINATION, MONTH & YEAR****Course Code: 222ECE001****ADVANCED METAL STRUCTURES**

Max. Marks: 60

Duration: 2.5 hours

**PART A****Answer all questions. Each question carries 5 marks**

1. Why are HSFG bolts preferred in joints subjected to fatigue? What do you mean by Prying action?
2. Discuss the advantages and disadvantages of welded connections over bolted connections.
3. What is local buckling of thin elements and what do you mean by post buckling strength of light gauge steel members?
4. Compare and contrast the constitutive relationship between Structural steel and Aluminium alloys along with a plot showing the stress-strain relationships of both the materials.
5. Explain sway and non-sway frames. Include at least two examples of each type using appropriate figures.

**PART B****Answer any five questions. Each question carries 7 marks**

6. Design a seat connection for a factored beam end reaction of 110kN. The beam section is ISMB 250 @ 36.6 kg/m connected to the flange of column section ISHB 200 @ 36.6 kg/m. Use Fe 410 grade steel and bolt 4.6 grade.
7. Design a welded stiffened seat and clip connection for an ISMB 350 @ 51.4 kg/m to transmit a factored end reaction 320 kN to a column ISHB 300 @ 57.6 kg/m. Steel Fe 410 grade and use fillet weld of required size.
8. Two channels of 180 mm x 80 mm section with bent lips as shown in figure 1 are connected with webs to act as beam. The thickness of the plate is 2.5 mm and the depth of the lip is 25mm. The beam has an effective span of 4.1 m. Determine the allowable load per m run on the beam. The dimensions in the figure 2 are in mm. Use  $f_y = 235 \text{ N/mm}^2$ .

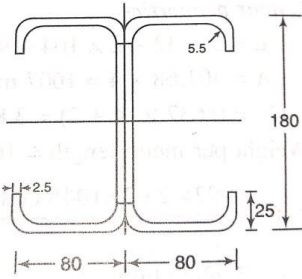

9. A light gauge rectangular box-section with overall cross-sectional dimensions of 200 mm x 150 mm (out-to-out), thickness 2.5 mm and fillets of radius 2.5 mm at each of the 4 inside corners, is being employed as a column over an effective length of 3.2 m. Compute the safe load on the column if steel used is having yield stress of 2400 kg/cm<sup>2</sup>.
10. Design a tension member using ALE H30 for carrying axial pull of 70 kN. The angles are connected back-to-back on both sides of a gusset plate using 16mm diameter bolts.
11. Explain the knees and valleys in the steel structures with neat figures.
12. A hand operated 50 kN overhead crane is provided in a workshop. The details are given below: i) Centre to centre between gantry girders = 16 m (ii) Span of the gantry girder = 6 m (iii) Weight of the crane = 40 kN Gantry (iv) Wheel spacing = 3 m (v) Weight of the crab = 10 kN (vi) Maximum edge distance = 1 m. Design a simply supported gantry girder, assuming the flange is laterally supported.

## Syllabus

### Module 1

Bolted connection – types, failure modes. Types of bolts. Design of seat angle, Web angle and end plate connections, Beam and column bolted splices.

Design of framed beam connection – continuous beam to beam connection.

### Module 2

Welded connection, Structure and properties of weld metal. Beam to-column connections-Angle seat, Stiffened beam seat connection, Web angle and end plate connections, Beam and column welded splices. Tubular connections -Curved weld length at intersection of tubes – SHS and RHS tubes - design parameters- Weld defects.

**Module 3**

Light gauge steel structures– Types of crosssections, Local and post buckling of thin elements, Stiffened and multiple stiffened compression elements, Tension members, Beams, Combined stresses and connections

**Module 4**

Aluminium Structures - Stress-strain relationship – Permissible stresses – Tension members, compression members, beams – Blast, impact, fire loads, Fire load calculation, Fire resistant design.

**Module 5**

Industrial structures, Design of members, Sway and non-sway frames, bracings, and bents. Rigid frame joints - Knees for rectangular frames and pitched roofs - Knees with curved flanges. Valley joints - Rigid joints in multistorey buildings. Vierendeel girders, Gantry girders - Loading considerations, Design of gantry girders.

**Course Plan**

No	Topic	No. of Lectures
1	<b>Bolted Connections(8)</b>	
1.1	Classification (Simple, Rigid, Semi rigid); Moment rotation Characteristics - Failure modes of a joint	1
1.2	Types of bolts - Bearing and High strength bolts- Prying force. Beam to Column connections -	1
1.3	Design of seat angle - Unstiffened	1.5
1.4	Design of seat angle – Stiffened	1.5
1.5	Web angle & end plate connections,	1
1.6	Beam and column bolted splices.	1
1.7	Design of framed beam connection – continuous beam to beam connection	1
2	<b>Welded Connections(8)</b>	
2.1	Structure and properties of weld metal. Beam to-column connections-Angle seat,	1.5
2.2	Stiffened beam seat connection,	1.5
2.3	Web angle and end plate connections,	1.5
2.4	Beam and column welded splices.	1.5
2.5	Tubular connections - Parameters of an in plane joint Welds in tubular joints	1
2.6	Curved weld length at intersection of tubes – SHS and RHS	1

	tubes - design parameters- Weld defects.	
3	<b>Design of Light Gauge Structures(8)</b>	
3.1	Design of light gauge steel structures: Introduction – Types of cross sections – Materials–	1
3.2	Local and post buckling of thin elements	1
3.3	Stiffened and multiple stiffened compression elements	2
3.4	Tension members	1
3.5	Beams and deflection of beams	1.5
3.6	Combined stresses and connections	1.5
4	<b>Aluminium structures, Fire resistant structures(8)</b>	
4.1	Design of Aluminium Structures: Introduction – Stress-strain relationship – Permissible stresses –	1
4.2	Tension members and Compression members	1
4.3	Design of Aluminium Beams	1
4.4	Blast loads - impact loads-	1
4.5	Ice-infested loads on structures-	1
4.6	fire loads-	1
4.7	fire-resistant design	1
4.8	Simple problems in Fire loads calculations	1
5	<b>Design of Industrial buildings and Gantry girders(8)</b>	
5.1	Design of members subjected to lateral loads and axial loads.	1
5.2	Sway and non-sway frames, bracings, and bents.	1
5.3	Rigid frame joints - Knees for rectangular frames and pitched roofs - Knees with curved flanges.	1
5.4	Valley joints - Rigid joints in multistorey buildings - Vierendeel girders.	1
5.5	Design of gantry girders - Introduction - Loading consideration- Selection of gantry girder.	1
5.6	Position of moving load for maximum effects, profile of gantry girder, limitation on vertical deflection	1
5.7	Design of gantry girders	2

### Reference Books

1. Gaylord., Design of steel structures, McGraw Hill, New York.
2. Duggal.S.K., Limit state design of steel structures, Tata McH
3. Subrahmanian.N, Design of steel structures, Oxford.
4. Wie-Wen Yu., Cold-Formed Steel Structures, McGraw Hill Book Company.
5. Hetherington. John and Smith P. D., Blast, and ballistic loading of structures,

CODE	COURSE NAME	CATEGORY	L	T	P	CREDIT
222ECE002	PROJECT PLANNING AND IMPLEMENTATION	PROGRAM ELECTIVE 3	3	0	0	3

**Preamble:** The course provides different stages of planning in construction. Knowledge about productivity analysis is also included. Students are introduced with quality management and cover the details of safety measures used in construction.

**Course Outcomes:** After the completion of the course on Project Planning and Implementation the student will be able to

<b>CO 1</b>	Describe the different stages of planning, tendering and execution of works in construction industry.
<b>CO 2</b>	Perform work study and analyse the productivity.
<b>CO 3</b>	Describe concepts of quality management, system requirements and documentation.
<b>CO 4</b>	Describe the objectives, techniques for testing and analysis and application of tools for improvement of quality.
<b>CO 5</b>	Explain the fundamentals of safety management systems in construction industry and demonstrate safety management systems in construction projects.

#### Mapping of course outcomes with program outcomes

	PO 1	PO 2	PO 3	PO 4	PO 5	PO 6	PO 7
<b>CO 1</b>			1				
<b>CO 2</b>	1		2	1			
<b>CO 3</b>			1				
<b>CO 4</b>			1				
<b>CO5</b>			1				

(1-Weak, 2-Medium, 3- strong)

#### Assessment Pattern

Bloom's Category	End Semester Examination
Remember	15
Understand	20
Apply	25
Analyse	

**Mark distribution**

<b>Total Marks</b>	<b>CIE</b>	<b>ESE</b>	<b>ESE Duration</b>
100	40	60	2.5 hours

**Continuous Internal Evaluation Pattern:**

Preparing a review article based on peer reviewed original publications (minimum 10 publications shall be referred): 15 marks  
 Course based task/Seminar/Data collection and interpretation: 15 marks  
 Test paper, 1 no.: 10 marks  
 Test paper shall include minimum 80% of the syllabus.

**End Semester Examination Pattern:**

The end semester examination will be conducted by the respective College. There will be two parts; Part A and Part B. Part A will contain 5 numerical/short answer questions with 1 question from each module, having 5 marks for each question (such questions shall be useful in the testing of knowledge, skills, comprehension, application, analysis, synthesis, evaluation and understanding of the students).

Students should answer all questions. Part B will contain 7 questions (such questions shall be useful in the testing of overall achievement and maturity of the students in a course, through long answer questions relating to the theoretical/practical knowledge, derivations, problem solving and quantitative evaluation), with minimum one question from each module of which student should answer any five. Each question can carry 7 marks.

**Note:** The marks obtained for the ESE for an elective course shall not exceed 20% over the average ESE mark % for the core courses. ESE marks awarded to a student for each elective course shall be normalized accordingly. For example, if the average end semester mark % for a core course is 40, then the maximum eligible mark % for an elective course is  $40 + 20 = 60\%$ .

**Model Question Paper**

**QP CODE:**

**Reg No.:** \_\_\_\_\_

**Name:** \_\_\_\_\_

**APJ ABDUL KALAM TECHNOLOGICAL UNIVERSITY SECOND SEMESTER  
M.TECH. DEGREE EXAMINATION, MONTH & YEAR**

**Course Code:222ECE002**

**PROJECT PLANNING AND IMPLEMENTATION**

Max. Marks: 60

Duration: 2.5 hours

**PART A**

(Answer **ALL** questions; each question carries 5 marks)

1. Explain different stages of planning by different agencies?
2. Explain different steps of work study.
3. Discuss basic elements of quality.
4. Discuss ISO standards for quality management.
5. Write notes on measurement of safety.

**PART B**

(Answer **any FIVE** questions; each question carries 7 marks)

6. Explain briefly the tendering process.
  7. Discuss Motivation, Leadership and Communication.
  8. Write notes on quality assurance techniques.
  9. Explain how quality control can be done in an organization.
  10. Explain different TQM models.
  11. Enumerate the different elements for Maintaining Safety in Construction.
  12. Explain human factors in construction safety.
-

**Module 1**

Project Planning: Objectives of planning-stages of planning by different agencies – sanctions-tendering –contracts-execution of works – measurements – disputes-arbitration

**Module 2**

Work and Productivity Analysis: Work study - factors influencing productivity - measurement of productivity – productivity improvement techniques - human relations - motivation leadership – communication

**Module 3**

Quality in Construction: Evolution of Quality-inspection, quality control and quality assurance in projects-factors affecting quality of construction

**Module 4**

Quality Management: ISO standards-TQM in Construction - Principles of TQM-Different TQM models

**Module 5**

Safety in Construction: Importance of safety-causes of accidents-human factors in construction safety management-safety in various construction operations-safety codes-safety committee and inspection-measuring of safety-approaches to improve safety in construction

**Course Plan**

No	Topic	No. of Lectures
1	<b>MODULE I (8 hours)</b>	
1.1	Project Planning:Objectives of planning-stages of planning by different agencies	2
1.2	Sanctions required-tendering- contracts	2
1.3	Execution of works-measurements	2
1.4	Disputes-arbitration	2
2	<b>MODULE II ( 10 hours)</b>	
2.1	Work and Productivity Analysis:Work study steps- Procedure of work study	2
2.2	Factors influencing productivity	2



2.3	Measurement of productivity- productivity improvement techniques	2
2.4	Human relations-motivation	2
2.5	Leadership – communication	2
3	<b>MODULE III (7 hours)</b>	
3.1	Quality in Construction:Evolution of Quality	1
3.2	Inspection, quality control in projects	2
3.3	Quality assurance in projects	2
3.4	Factors affecting quality of construction	2
4	<b>MODULE IV (6 hours)</b>	
4.1	ISO standards	2
4.2	TQM in construction- Principles of TQM	2
4.3	Different TQM models	2
5	<b>MODULE V (9 hours)</b>	
5.1	Safety in Construction :Importance of safety-causes of accidents	2
5.2	human factors in construction safety management	1
5.3	Safety in various construction operations	2
5.4	Safety codes	1
5.5	Safety committee and inspection-measuring of safety	2
5.6	Approaches to improve safety in construction	1

### Reference Books

1. Sengupta and H. Guha (1995), “Construction Management and Planning”, Tata McGraw Hill Publishing Company Pvt. Ltd. New Delhi.
2. Clarkson Oglesby, Henry Parker (1989), Gregory Howell, “Productivity improvement in construction”, McGraw Hill Book Company.
3. S. Seetharaman, “Construction Engineering and Management”, Umesh publications.
4. Kumar NeerajJha, “Construction Project Management- Theory and Practice”, Pearson Education India
5. R.P. Mohanty and R.R. Lakhe, “Total quality management”, Jaico publishing house
6. K.N.Vaid, “Construction Safety Management”, National Institute of Construction Management and Research.

CODE	COURSE NAME	CATEGORY	L	T	P	CREDIT
222ECE003	CONSTRUCTION PERSONNEL MANAGEMENT	PROGRAM ELECTIVE 3	3	0	0	3

**Preamble:** On completion of this course the students will know various processes in manpower planning, organizational, welfare measures and various strategic approaches in construction industry.

**Course Outcomes:** After the completion of the course on Construction Personal Management the student will be able to

<b>CO 1</b>	Study the various functions of human resource management such as man power planning, organizing, staffing, directing and controlling.
<b>CO 2</b>	Describe the organization structure and the recruitment strategies.
<b>CO 3</b>	Explain the team work, intergroup behaviour and conflicts in organization.
<b>CO 4</b>	Study the employee performance management, training and development processes
<b>CO 5</b>	Describe the various strategic approaches to manage human resources in construction industry.

#### Mapping of course outcomes with program outcomes

	PO 1	PO 2	PO 3	PO 4	PO 5	PO 6	PO 7
<b>CO 1</b>	1		1				
<b>CO 2</b>			1				
<b>CO 3</b>			1		1		
<b>CO 4</b>			2				1
<b>CO 5</b>			1				

(1- Weak, 2-Medium, 3- strong)

**Assessment Pattern**

<b>Bloom's Category</b>	<b>End Semester Examination</b>
Remember	10
Understand	20
Apply	30
Analyse	
Evaluate	
Create	

**Mark distribution**

<b>Total Marks</b>	<b>CIE</b>	<b>ESE</b>	<b>ESE Duration</b>
100	40	60	2.5 hours

**Continuous Internal Evaluation Pattern:**

Preparing a review article based on peer reviewed original publications (minimum 10 publications shall be referred): 15 marks  
 Course based task/Seminar/Data collection and interpretation: 15 marks  
 Test paper, 1 no.: 10 marks  
 Test paper shall include minimum 80% of the syllabus.

**End Semester Examination Pattern:**

The end semester examination will be conducted by the respective College. There will be two parts; Part A and Part B. Part A will contain 5 numerical/short answer questions with 1 question from each module, having 5 marks for each question (such questions shall be useful in the testing of knowledge, skills, comprehension, application, analysis, synthesis, evaluation and understanding of the students).

Students should answer all questions. Part B will contain 7 questions (such questions shall be useful in the testing of overall achievement and maturity of the students in a course, through long answer questions relating to theoretical/practical knowledge, derivations, problem solving and quantitative evaluation), with minimum one question from each module of which student should answer any five. Each question can carry 7 marks. Total duration of the examination will be 150 minutes.

**Note:** The marks obtained for the ESE for an elective course shall not exceed 20% over the average ESE mark % for the core courses. ESE marks awarded to a student for each elective course shall be normalized accordingly. For example, if the average end

semester mark % for a core course is 40, then the maximum eligible mark % for an elective course is  $40+20 = 60$  %.

### Model Question Paper

QP CODE:

Reg No.: \_\_\_\_\_

Name: \_\_\_\_\_

**APJ ABDUL KALAM TECHNOLOGICAL UNIVERSITY SECOND SEMESTER  
M.TECH. DEGREE EXAMINATION, MONTH & YEAR**

**Course Code: 222ECE003**

**CONSTRUCTION PERSONNEL MANAGEMENT**

Max. Marks: 60

Duration: 2.5 hours

PART A

(Answer **ALL** questions; each question carries 5 marks)

1. Explain with a flow chart the process of staffing in an organisation.
2. Recommend the importance of span of control in an organization.
3. Explain the conflicts in a construction organization.
4. Enumerate different performance appraisal methods and assessment.
5. Explain briefly the challenges facing the construction industry in India.

PART B

(Answer **any FIVE** questions; each question carries 7 marks)

6. As a personnel manager how can you direct and control employees in the field of construction and explain the functions of a supervisor in an organisation.
7. What are the different sources of recruitment in an organization? Explain the recruitment process.
8. Illustrate the role of organisation charts and explain different types of organization structures in detail.
9. Write detailed note on job description in an organization. Prepare a report containing the job description and job analysis details of an imaginary construction organisation.

10. What is 360 degree performance appraisal? Explain the significance of self appraisal for an individual in an organisation.
11. Explain in detail the total quality management and its elements.
12. Enumerate the various strategic approaches for managing human resources in construction industry.

\*\*\*\*\*

## **Syllabus**

### **Module 1: MANPOWER PLANNING**

Manpower Planning, Organizing, Staffing, directing, and controlling – Estimation of

Man power requirement – Factors influencing supply and demand of human resources – Role of HR manager – Personnel Principles.

### **Module 2: ORGANIZATION**

Organization structure – Organization charts – Staffing Plan - Development and Operation of human resources – Recruitment – Selection strategies – Placement and Training.

### **Module 3: HUMAN RELATIONS AND ORGANIZATIONAL BEHAVIOUR**

Basic individual psychology – Approaches to job design and job redesign – Self managing work teams – Intergroup – Conflict in organizations – Leadership-Engineer as Manager – all aspects of decision making – Significance of human relation and organizational – Individual in organization – Motivation – Group dynamics, Team working – Communication for people management.

### **Module 4: MANAGEMENT AND DEVELOPMENT METHODS**

Compensation : Wages and Salary, Employee benefits, Employee appraisal and assessment – Employee services – Safety and Health Management – Innovative approach to designing and managing organization – Total Quality Management – Levels of change in the organizational Development – Requirements of organizational Development - New methods of training and development – Performance Management.

### **Module 5: STRATEGIC APPROACHES IN CONSTRUCTION INDUSTRY**

Introduction: the challenges of managing people in construction-Strategic approaches to managing human resources in the construction industry-Employee relations-Employee participation, involvement and empowerment in construction.

**Course Plan**

<b>No</b>	<b>Topic</b>	<b>No. of Lectures</b>
1	<b>MANPOWER PLANNING (7)</b>	
1	Manpower Planning, Organizing, Staffing, directing, and controlling	2
1.2	Estimation of Man power requirement	2
1.3	Factors influencing supply and demand of human resources	1
1.4	Role of HR manager	1
1.5	Personnel Principles	1
2	<b>ORGANIZATION (7)</b>	
2.1	Organization structure	1
2.2	Organization charts	1
2.3	Staffing Plan	1
2.4	Development and Operation of human resources	1
2.5	Recruitment	1
2.6	Selection strategies	1
2.7	Placement and Training	1
3	<b>HUMAN RELATIONS AND ORGANIZATIONAL BEHAVIOUR (10)</b>	
3.1	Basic individual psychology	1
3.2	Approaches to job design and job redesign	1
3.3	Self managing work teams	1
3.4	Intergroup, Conflict in organizations	1
3.5	Leadership, Engineer as Manager, All aspects of decision making	2
3.6	Significance of human relation and organizational	1
3.7	Individual in organization, Motivation	1

3.8	Group dynamics, Team working	1
3.9	Communication for people management	1
4	<b>MANAGEMENT AND DEVELOPMENT METHODS (9)</b>	
4.1	Compensation: Wages and Salary, Employee benefits, Employee appraisal and assessment	1
4.2	Employee services	1
4.3	Safety and Health Management	1
4.4	Innovative approach to designing and managing organization	1
4.5	Total Quality Management	1
4.6	Levels of change in the organizational Development	1
4.7	Requirements of organizational Development	1
4.8	New methods of training and development	1
4.9	Performance Management	1
5	<b>STRATEGIC APPROACHES IN CONSTRUCTION INDUSTRY (7)</b>	
5.1	Introduction: the challenges of managing people in construction	2
5.2	Strategic approaches to managing human resources in the construction industry	2
5.3	Employee relations	1
5.4	Employee participation, involvement and empowerment in construction	2

### Reference Books

1. Charles D Pringle, Justin Gooderi Longenecter, Management, CE Merril Publishing Co.1981.
2. Dwivedi R.S, Human Relations and Organisational Behaviour, Mac millian India Ltd.,2005.
3. Josy.J. Familiaro, Handbook of Human Resources Administration, McGraw-Hill International Edition, 1987.

4. Memoria,C.B., Personnel Management, Himalaya Publishing Co., 1997.
5. Carleton Counter II and Jill Justice Coutler, The Complete Standard Handbook of Construction Personnel Management, Prentice-Hall, Inc., 1989.
6. Martin Loosemore, Andrew Dainty and Helen Lingard, Human resource management in construction projects- Strategic and operational approaches, Spon Press, Taylor & Francis Group, 2003.

APJ ABDUL KALAM  
TECHNOLOGICAL  
UNIVERSITY





APJ ABDUL KALAM  
TECHNOLOGICAL  
UNIVERSITY

---

**SEMESTER II**

---

**PROGRAM ELECTIVE IV**

---

Estd.



2014

CODE	COURSE NAME	CATEGORY	L	T	P	CREDIT
222ECE006	ADVANCED DESIGN OF FOUNDATION	PROGRAM ELECTIVE 4	3	0	0	3

**Preamble:** This course exposes the students to the various aspects of foundation analysis and design. The course covers soil exploration techniques; and, design of shallow and deep foundations. Design of machine foundation is also included in the course.

**Course Outcomes:** The COs shown are only indicative.

After the completion of the course the student will be able to

<b>CO 1</b>	Compute the geotechnical design parameters of foundation
<b>CO 2</b>	Design the shallow foundations
<b>CO 3</b>	Assess the load carrying capacity of the pile and design the pile foundation
<b>CO 4</b>	Identify and design the components of well foundation
<b>CO 5</b>	Design foundation for vibrating machines

#### Mapping of course outcomes with program outcomes

	PO 1	PO 2	PO 3	PO 4	PO 5	PO 6	PO 7
<b>CO 1</b>	2		2				
<b>CO 2</b>	2		3	2	1		
<b>CO 3</b>	2		3	2	1		
<b>CO 4</b>	2		3				
<b>CO 5</b>	2		3	2	1		

(1- Weak, 2-Medium, 3- strong)

#### Assessment Pattern

Bloom's Category	End Semester Examination
Apply	40
Analyse	20
Evaluate	-
Create	-

#### Mark distribution

Total Marks	CIE	ESE	ESE Duration
100	40	60	2.5 hours

**Continuous Internal Evaluation Pattern:**

Micro project/Course based project: 20 marks

Course based task/Seminar/Quiz: 10 marks

Test paper, 1 no.: 10 marks

The project shall be done individually. Group projects not permitted.

Test paper shall include minimum 80% of the syllabus

**End Semester Examination Pattern:**

The end semester examination will be conducted by the respective College. There will be two parts; Part A and Part B. Part A will contain 5 numerical/short answer questions with 1 question from each module, having 5 marks for each question (such questions shall be useful in the testing of knowledge, skills, comprehension, application, analysis, synthesis, evaluation and understanding of the students).

Students should answer all questions. Part B will contain 7 questions (such questions shall be useful in the testing of overall achievement and maturity of the students in a course, through long answer questions relating to theoretical/practical knowledge, derivations, problem solving and quantitative evaluation), with minimum one question from each module of which student should answer any five. Each question can carry 7 marks. Total duration of the examination will be 150 minutes.

**Note:** The marks obtained for the ESE for an elective course shall not exceed 20% over the average ESE mark % for the core courses. ESE marks awarded to a student for each elective course shall be normalized accordingly. For example, if the average end semester mark % for a core course is 40, then the maximum eligible mark % for an elective course is  $40+20 = 60\%$ .

**Model Question Paper****QP CODE:****Reg No.:** \_\_\_\_\_**Name:** \_\_\_\_\_**APJ ABDUL KALAM TECHNOLOGICAL UNIVERSITY SECOND SEMESTER  
M.TECH. DEGREE EXAMINATION, MONTH & YEAR****Course Code: 222ECE006****ADVANCED DESIGN OF FOUNDATION**

Max. Marks: 60

Duration: 2.5 Hours

**PART A*****Answer all questions; each question carries 5 marks***

1. Write a note on split spoon sampler and scraper bucket sampler.
2. What is the effect of size on the settlement of footings on homogeneous sand deposits.
3. Discuss the different types of vertical load tests on single pile.
4. A single tube circular well foundation of 3.5 m diameter is installed to a depth of 7m below the scour level in granular soil. The corrected standard penetration value (N value) in the bearing stratum is 60. Estimate the allowable bearing pressure of the well foundation.
5. Give general requirements of machine foundations.

**PART B*****Answer any five questions; each question carries 7 marks***

6. Explain on various geophysical methods employed in the field. Also explain their uses and limitations.
7. Design a combined footing for two columns with loads 3500kN and 4500kN. The centre to centre distance between columns is 6m. Columns are having cross sections of 500mm x 500mm. There is a restriction on projection of footing on both column sides by 0.4m from the face of the column. Take allowable soil pressure as 200kN/m<sup>2</sup>.
8. A rectangular footing of dimensions 2.5 m X 3 m in plan is founded at a depth of 1.5 m below the ground level. The load on the footing acts at an angle of 15° to the vertical and is eccentric in the direction of the width by 10 cm. The saturated unit weight of soil is 18 kN/m<sup>3</sup>.  $C' = 15$  kN/m<sup>2</sup>,  $\Phi' = 30^\circ$ . Water table is at a depth of 2m below the ground surface. Use IS 6403-1981 recommendations to calculate the net ultimate bearing capacity. For  $\Phi' = 30^\circ$ ,  $N_c = 30.14$ ,  $N_q = 18.4$ ,  $N_\gamma = 22.4$

9. A precast concrete pile of size 45x45 cm is driven into stiff clay. The unconfined compressive strength of the clay is 200kN/m<sup>2</sup>. Determine the length of pile required to carry a safe working load of 400kN with F.S= 2.5
  10. A group of 9 piles was driven into soft clay extending from ground level to a great depth. The diameter and length of piles were 30cm and 10m respectively. The unconfined compressive strength of clay is 50kPa. If the piles were placed 90cm centre to centre. Compute the allowable load on the pile group on the basis of shear failure criterion for F.S of 2.5
  11. Explain the components of well foundations and its functions with a neat sketch. Explain different forces acting on well foundations
  12. Write down the design criteria for machine foundation. Also explain the construction aspects of design of machine foundation.
- 

## Syllabus

### Module I

Soil Exploration and testing: Methods of exploration-Boring, Sampling of soils, Bore log - Standard penetration Test-Field Vane shear Test-Static Cone Penetration Test - Dynamic Cone penetration tests - Field CBR test - Plate Load Test, Geophysical Methods, Soil report, Bore hole Log

Classification of Foundations - factors influencing the choice of foundations

Geotechnical design parameters- Bearing capacity – Methods by Terzaghi, Meyerhoff, Hansen and IS Code - Correlation of bearing capacity from penetration test data

### Module II

Contact pressure distribution beneath rigid and flexible footings on sand and clay – modulus of subgrade reaction

Settlement of foundations-immediate settlement –consolidation settlement-Total and differential settlement-causes –permissible settlements

Proportioning of Foundations for equal settlement, loads for design- concepts of net and gross loads, depth of foundation,

Analysis of shallow foundations in clay and sand - individual and combined footings, and rafts - floating and partially compensated.

### Module III

Pile foundation- Classification of pile foundation - friction piles, end bearing piles, laterally loaded piles

Evaluation of vertical stresses in soil – friction piles in clay , end bearing pile in on rock, piles driven through clay into strong strata

Estimation of pile capacity of individual piles - static formula, dynamic formulae and IS method – negative skin friction

Field test on piles – vertical load test, pull out test, lateral load test, dynamic load test, non-destructive tests

Pile groups - Consideration regarding spacing - Efficiency of pile groups – Structural design of pile and Pile Cap

Design aspects of piled raft foundation for settlement reduction and load transfer

#### **Module IV**

Caissons and well foundations – Elements of well foundations

Types of well foundation - open caissons, pneumatic caissons, floating caissons, well foundations, monoliths

Sinking stresses in well foundation

Design of well cap, well steining, well curb, cutting edge and bottom plug

#### **Module V**

Machine Foundations - Types of machines and machine foundation - Basic principles of design of machine foundation

Vibration Analysis for machine foundation - Elastic half space theory for rigid footings.

IS Code practice for design of machine foundation for reciprocating and impact type machines

#### **Course Plan**

No	Topic	No. of Lectures
1	<b>Module I : Total lecture hours : 8</b>	
1.1	Soil exploration and Testing methods	3
1.2	Interpretation of soil report	1
1.2	Classification of foundation, factors influencing choice of foundation	1
1.4	Bearing capacity by Terzaghi, Meyerhoff, Hasen and IS code methods	2
1.5	Correlation of bearing capacity from penetration data	1
2	<b>Module II : Total lecture hours : 9</b>	
2.1	Contact pressure distribution beneath rigid and flexible	1

	footings on sand and clay	
2.2	Modulus of subgrade reaction	1
2.3	Settlement of foundations-immediate settlement – consolidation settlement - total and differential settlement-causes –permissible settlements	1
2.4	Proportioning of Foundations for equal settlement, loads for design - concepts of net and gross loads, depth of foundation	2
2.5	Analysis of shallow foundations in clay and sand – Individual combined footings and rafts – floating and partially compensated	4
3	<b>Module III : Total lecture hours : 9</b>	
3.1	Classification of pile foundation - friction piles, end bearing piles, laterally loaded piles	1
3.2	Evaluation of vertical stresses in soil – friction piles in clay, end bearing pile in on rock, piles driven through clay into strong strata	1
3.3	Estimation of pile capacity of individual piles - static formula, dynamic formulae and IS method – negative skin friction	1
3.4	Field test on piles – vertical load test, pull out test, lateral load test, dynamic load test, non-destructive tests	2
3.5	Pile groups - Consideration regarding spacing - Efficiency of pile groups	1
3.6	Structural design of pile and Pile Cap	2
3.7	Design aspects of piled raft foundation for settlement reduction and load transfer	1
4	<b>Module IV : Total lecture hours : 6</b>	
4.1	Introduction to well foundations – Elements of well foundations	1
4.2	Different types of well foundations	1
4.3	Sinking stresses in wells	1
4.4	Design of well cap, well steining, well curb, cutting edge and bottom plug	3
5	<b>Module V : Total lecture hours : 8</b>	
5.1	Types of machines and machine foundation	1
5.2	Basic principles of design of machine foundation	1

5.3	Vibration Analysis for machine foundation - Elastic half space theory for rigid footings	2
5.4	IS Code practice for design of machine foundation for reciprocating machines	2
5.5	IS Code practice for design of machine foundation for impact type machines	2

### Reference Books

1. Varghese P.C, Foundation Engineering, Prentice Hall India, New Delhi 2005
2. Swami Saran, Analysis and design of substructures, Oxford and IBH Publishing Company Pvt. Ltd.
3. Punmia B C, "Soil Mechanics and Foundations", Laxmi Publications Pvt Ltd, New Delhi
4. Joseph E. & Bowles, "Foundation Analysis & Design", McGraw Hill
5. Kurian N P, "Design of foundation systems", Narosa Publishing House, Madras
6. Arora K.R., "Soil Mechanics & Foundation Engineering", Standard Publishers Distributors, New Delhi



CODE	COURSE NAME	CATEGORY	L	T	P	CREDIT
222ECE007	DESIGN OF BRIDGES	PROGRAM ELECTIVE 4	3	0	0	3

**Preamble:** This course provides the fundamental aspects of RC bridges. The students are exposed to the load transfer mechanisms, analysis methodologies and design principles of bridge structures and its components.

**Course Outcomes:** After the completion of the course the student will be able to

<b>CO 1</b>	Discuss the classification of bridges, codal provisions for road bridges and load acting in the bridges
<b>CO 2</b>	Illustrate the methods of bridge deck analysis and methods of lateral load distribution
<b>CO 3</b>	Design RC Slab bridges and T-Beam bridges for the given loading
<b>CO 4</b>	Design various Substructure elements of the RCC Bridges
<b>CO 5</b>	Design bridge bearings and joints

#### Mapping of course outcomes with program outcomes

	PO 1	PO 2	PO 3	PO 4	PO 5	PO 6	PO 7
<b>CO 1</b>			1	1			
<b>CO 2</b>			2	1			
<b>CO 3</b>			3	2	1		
<b>CO 4</b>			3	2	1		
<b>CO 5</b>			3	2	1		

(1- Weak, 2-Medium, 3- strong)

#### Assessment Pattern

Bloom's Category	End Semester Examination
Remember	15
Understand	20
Apply	25
Analyse	

#### Mark distribution

Total Marks	CIE	ESE	ESE Duration
100	40	60	2.5 hours

**Continuous Internal Evaluation Pattern:**

Preparing a review article based on peer reviewed

original publications (minimum 10 publications shall be referred): 15 marks

Course based task/Seminar/Data collection and interpretation: 15 marks

Test paper, 1 no.: 10 marks

Test paper shall include minimum 80% of the syllabus.

**End Semester Examination Pattern:**

The end semester examination will be conducted by the respective College. There will be two parts; Part A and Part B. Part A will contain 5 numerical/short answer questions with 1 question from each module, having 5 marks for each question (such questions shall be useful in the testing of knowledge, skills, comprehension, application, analysis, synthesis, evaluation and understanding of the students).

Students should answer all questions. Part B will contain 7 questions (such questions shall be useful in the testing of overall achievement and maturity of the students in a course, through long answer questions relating to theoretical/practical knowledge, derivations, problem solving and quantitative evaluation), with minimum one question from each module of which student should answer any five. Each question can carry 7 marks.

**Note:** The marks obtained for the ESE for an elective course shall not exceed 20% over the average ESE mark % for the core courses. ESE marks awarded to a student for each elective course shall be normalized accordingly. For example, if the average end semester mark % for a core course is 40, then the maximum eligible mark % for an elective course is  $40+20 = 60\%$ .



**Model Question Paper****QP CODE:****Reg No.:** \_\_\_\_\_**Name:** \_\_\_\_\_**APJ ABDUL KALAM TECHNOLOGICAL UNIVERSITY SECOND SEMESTER  
M.TECH. DEGREE EXAMINATION, MONTH & YEAR****Course Code: 222ECE007****DESIGN OF BRIDGES****Max. Marks: 60****Duration: 2.5 hours****PART A****(Answer ALL questions; each question carries 5 marks)**

1. Describe the different components of a bridge using neat figures
2. Explain the method of grillage analysis of bridge decks.
3. List the steps in designing RCC culverts.
4. Explain briefly the types of bridge foundations.
5. List and explain the types of bridge bearings.

**PART B****(Answer any FIVE questions; each question carries 7 marks)**

6. Explain the different types of bridges.
7. Explain the different types of loading on a bridge.
8. Explain briefly the method lateral load distribution using Courbon's Method.
9. Design a solid slab bridge superstructure having a clear span of 8.0 metres and carriageway of 4.5 metres with 1.2 metres wide footway on either side for a National Highway. Loading: Single lane of IRC Class AA tracked. Use M30 Concrete and Fe500 steel.
10. Design a the deck slab and outer girder of a T-Beam bridge with 9 mclear roadway and having a simply supported span of 12.0 m between centre line of bearings. The deck may consist of 3 girders spaced at 2 .45 m centres. Loading-Single lane of Class Awheeled loading. Use M30 Concrete and Fe500 steel.

11. Design pier cap for a bridge having total width of 9 m. Diameter of the pier is 2 m. Use single lane of IRC Class AA tracked loading. Use M35 Concrete and Fe500 steel.
12. Design an elastomeric bearing to suit the following data:
- Vertical load (sustained) : 300 kN
  - Vertical load (dynamic): 35 kN
  - Horizontal force: 50 kN
  - Modulus of rigidity of elastomer : 1 MPa

\*\*\*\*\*

### Syllabus

#### Module 1

##### **Fundamentals of Bridge Design** – Introduction - Bridge components

Classification of bridges –simple culverts –Solid slab bridges - simply supported beam bridges – Continuous beam bridges – arch bridges – box girder bridges- cable stayed bridges- suspension bridges

Loads - dead and imposed loads-dynamic effect-wind and seismic forces- longitudinal and centrifugal forces-hydraulic forces-earth pressure-temperature effect and secondary stresses – prestressing - General design requirements

#### Module 2

**Bridge Deck Analysis** Thin plate theory – grillage analysis – finite element analysis

**Method of Lateral load Distribution**-Pigeaud's Method-Effective Width Method-Courbon's Method-Hendry Jaegar method

#### Module 3

**Design of Simple RC Bridges**Design of solid slab bridge– Design of Simply Supported RC T-Beam bridge

#### Module 4

##### **Bridge substructure**

Piers and Pier caps – types - Design

Abutments – types – loading – seismic effect – design considerations

Introduction to Bridge Foundation – types and design considerations

## Module 5

**Bridge Bearings** – types – Design of elastomeric bearings

**Joints** – uses and types

## Course Plan

No	Topic	No. of Lectures
<b>1</b>	<b>Fundamentals of Bridge Design</b>	
1.1	Introduction - Bridge components	1
1.2	Classification of bridges – simple culverts - simply supported beam bridges – Continuous beam bridges – arch bridges – box culvert – cable stayed - suspension	3
1.3	Loads - dead and imposed loads -dynamic effect-wind and seismic forces-longitudinal and centrifugal forces-hydraulic forces-earth pressure-temperature effect and secondary stresses – prestressing - General design requirements	3
<b>2</b>	<b>Bridge Deck Analysis and Method of Lateral load Distribution</b>	
2.1	Bridge deck analysis - Thin plate theory – grillage analysis – finite element analysis	3
2.2	Lateral load Distribution -Pigeaud’s Method-Effective Width Method- Courbon’s Method- Hendry Jaegar method	3
<b>3</b>	<b>Design of Simple RC Bridges</b>	
3.1	Design of solid slab bridge	4
3.2	Design of Simply Supported RC T-Beam bridge	5
<b>4</b>	<b>Bridge substructure</b>	
4.1	Design of Pier and pier cap	5
4.2	Design of Abutments	5
4.3	Introduction to Bridge Foundation – types and design considerations	2
<b>5</b>	<b>Bridge Bearings and Joints</b>	
5.1	Bridge Bearings – types – Design of elastomeric bearings	4
5.2	Joints – uses and types	2

**Reference Books**

1. Krishna Raju, N., Design of Bridges, Oxford and IBH Publishing Company, New Delhi.
2. Jagadeesh, T. R. and Jayaram, M. A., Design of Bridge Structures, PHI Learning Private Limited, New Delhi.
3. O'Brien, E. J., Keogh, D. L., O'Connor, A. J. and Lehane, B. M., Bridge Deck Analysis, CRC Press, New York.
4. Rakshit, K. S., Design and Construction of Highway Bridges, New Central Book Agency, Delhi.
5. Victor, D.J, "Essential of Bridge Engineering", Oxford and IBH Publishing Company, New Delhi.
6. Swami Saran, "Analysis and Design of Substructures", Oxford and IBH Publishing Company, New Delhi



CODE	COURSE NAME	CATEGORY	L	T	P	CREDIT
222ECE008	MAINTENANCE AND REHABILITATION OF STRUCTURES	PROGRAM ELECTIVE 4	3	0	0	3

**Preamble:** The course provides the basic knowledge about various distress and damage of structures. The course covers various maintenance, repair, and strengthening techniques of buildings. Also to study the durability aspects of buildings, causes and process of failure and rehabilitation methods. This course helps the students to investigate the cause of deterioration of concrete structures and decide about different repair strategies.

**Course Outcomes:** After the completion of the course the student will be able to

<b>CO 1</b>	Identify Various distress and damage of structures.
<b>CO 2</b>	Explain the cause of deterioration of concrete structures and methods of protection.
<b>CO 3</b>	Establish appropriate maintenance and repair strategy
<b>CO 4</b>	Explain the various repair materials and repair techniques which enable a structure to perform its designated function
<b>CO 5</b>	Explain the demolition sequence of buildings.

#### Mapping of course outcomes with program outcomes

	PO 1	PO 2	PO 3	PO 4	PO 5	PO 6	PO 7
<b>CO 1</b>	1		1				
<b>CO 2</b>			1				
<b>CO 3</b>			2				
<b>CO 4</b>			1				
<b>CO 5</b>			1		1		

(1- Weak, 2-Medium, 3- strong)

#### Assessment Pattern

Bloom's Category	End Semester Examination
Apply	25
Analyse	25
Evaluate	10
Create	

#### Mark distribution

Total Marks	CIE	ESE	ESE Duration
100	40	60	2.5 hours

**Continuous Internal Evaluation Pattern:**

Micro project/Course based project: 20 marks

Course based task/Seminar/Quiz: 10 marks

Test paper, 1 no.: 10 marks

The project shall be done individually. Group projects not permitted.

Test paper shall include minimum 80% of the syllabus

**End Semester Examination Pattern:**

The end semester examination will be conducted by the respective College. There will be two parts; Part A and Part B. Part A will contain 5 numerical/short answer questions with 1 question from each module, having 5 marks for each question (such questions shall be useful in the testing of knowledge, skills, comprehension, application, analysis, synthesis, evaluation and understanding of the students).

Students should answer all questions. Part B will contain 7 questions (such questions shall be useful in the testing of overall achievement and maturity of the students in a course, through long answer questions relating to theoretical/practical knowledge, derivations, problem solving and quantitative evaluation), with minimum one question from each module of which students should answer any five. Each question can carry 7 marks. Total duration of the examination will be 150 minutes.

**Note:** The marks obtained for the ESE for an elective course shall not exceed 20% over the average ESE mark % for the core courses. ESE marks awarded to a student for each elective course shall be normalized accordingly. For example, if the average end semester mark % for a core course is 40, then the maximum eligible mark % for an elective course is  $40 + 20 = 60\%$ .



Name-----

Reg:No-----

**AAPJ ABDUL KALAM TECHNOLOGICAL UNIVERSITY SECOND SEMESTER  
M.TECH. DEGREE EXAMINATION, MONTH & YEAR**

**Course Code: 222ECE008**

**MAINTENANCE AND REHABILITATION OF STRUCTURES**

Time:2.5 hrs

Max mark:60

**PART A**

***Answer all questions; each question carries 5 marks***

1. What are the needs for Rehabilitation of Structures?
2. Explain Cathodic protection.
3. Explain assessment procedure for evaluating damages in existing structures.
4. Discuss on Resin Mortar as a repair material.
5. Discuss the salient features of building demolition process.

**PART B**

***Answer any five questions; each question carries 7 marks***

6. How does concrete get affected by heat? Write in detail about thermal properties of concrete.
7. Discuss on the mechanism of corrosion in reinforcing steel.
8. Explain the various Facets of maintenance in concrete buildings.
9. Describe the properties and uses of Fibre reinforced concrete.
10. Write a note on special concrete elements used in repair works to attain early strength.
11. Describe the various underpinning methods and the circumstances with which it is provided.
12. Describe various strengthening techniques to overcome lower member strength in distressed structures.

-----

## SYLLABUS

CIVIL ENGINEERING-CE1

### **Module 1**

Influence on serviceability and durability, Need for Rehabilitation, quality assurance for concrete construction as built concrete properties- strength, permeability, thermal properties and cracking, Effects due to climate, temperature, chemicals, wear and erosion, frost action, Design and construction errors, Effects of cover thickness and cracking, concrete subjected to fire, chemical reactions responsible for the concrete deterioration, process of deterioration in structures and factors influencing.

### **Module 2**

Corrosion control and concrete protection- Chloride, sulphate and acid attack, carbonation, Corrosion in steel- various conditions of steel in concrete, Corrosion mechanism, Concrete surface treatments, Methods of corrosion protection.

### **Module 3**

Maintenance and Repair strategies- Objectives of maintenance, Facets, Factors influencing, benefits of good maintenance operation, Causes of deterioration in various materials, testing techniques, Inspection of property and reports, Maintenance budget estimation, Assessment procedure for evaluating a damaged structure, Purpose of investigating defects- aspects to be investigated.

### **Module 4**

Materials for repair- Special concrete and mortar, polymer concrete, sulphur infiltrated concrete, resin mortar, Expansive cement, Concrete chemicals, Ferrocement- casting techniques, application, Fibre reinforced concrete.

### **Module 5**

Techniques for repair- Rust eliminators and polymer coating for rebars, foamed concrete, mortar, dry pack, vacuum concrete, pre-packed aggregate, Guniting and Shotcrete, epoxy injection, stitching, mortar repair for cracks, shoring and underpinning, Repairs to overcome low member strength, Concrete removal and preparation for repair, Case studies.

Demolition of Buildings – Planning, Precautions and Protective measures indemolition Work-Sequence Of Operations.

**COURSE PLAN**

	<b>Topic</b>	<b>No. of Lectures</b>
1	<b>Influence on serviceability and durability</b>	
1.1	Introduction- Need for Rehabilitation, classification of buildings and structures, classification of loads acting on a structure, quality assurance for concrete construction as built concrete properties- strength, permeability, thermal properties and cracking	2
1.2	Effects due to climate, temperature, chemicals, wear and erosion, frost action, Design and construction errors, Effects of cover thickness and cracking, Effects of fire	3
1.3	Chemical reactions responsible for the concrete deterioration, Process of deterioration in structures and factors influencing	3
2	<b>Corrosion control and concrete protection</b>	
2.1	Chloride, sulphate and acid attack, carbonation, Corrosion in steel- various conditions of steel in concrete, Corrosion mechanism	3
2.2	Concrete surface treatments- liquid surface coatings, coatings on concrete to resist salt and water, resisting carbonation, Application of coatings, Corrosion inhibitors	3
2.3	Methods of corrosion protection- coatings to reinforcement, corrosion resistant steel, cathodic protection	2
3	<b>Maintenance and Repair strategies</b>	
3.1	Objectives of maintenance, Facets, Factors influencing, benefits of good maintenance operation	2
3.2	Causes of deterioration in various materials, testing techniques	3
3.3	Inspection of property and reports, Maintenance budget estimation, Assessment procedure for evaluating a damaged structure, Purpose of investigating defects, aspects to be investigated	3
4	<b>Materials for repair</b>	
4.1	Special concrete and mortar, polymer concrete, sulphur infiltrated concrete, resin mortar, Expansive cement	3
4.2	Concrete chemicals, special elements for accelerated strength gain	2
4.3	Ferrocement- casting techniques, application, Fibre reinforced concrete- fibres used, factors effecting the properties	2
5	<b>Techniques for repair</b>	
5.1	Rust eliminators and polymer coating for rebars during repair, foamed concrete, mortar, dry pack, vacuum concrete, Pre-packed aggregate, Guniting and Shotcrete Epoxy injection, Stitching, Mortar repair for cracks, shoring and underpinning.	3
5.2	Repairs to overcome low member strength, deflection, cracking, chemical disruption, weathering wear, fire, leakage, Concrete removal and preparation for repair	3

5.3	Case studies	2
5.4	Demolition of buildings – sequence of operations, protective measures.	1

### **Reference Books**

1. Denison Campbell, Allen and Harold Roper, Concrete Structures, Materials, Maintenance and Repair, Longman Scientific and Technical UK, 1991.
2. M.S. Shetty, Concrete Technology – Theory and Practice, S. Chand and Company, New Delhi, 1992.
3. R.T. Allen and S.C. Edwards, Repair of Concrete Structures, Blakie and Sons, UK, 1987.
4. R. D. Woodson, Concrete Structures- Protection, Repair and Rehabilitation, Butterworth-Heinemann, UK, 2009.
5. P. S. Gahlot, S. Sharma, Building Repair and Maintenance Management, CBS publishers, New Delhi, 2013
6. Forensic Structural Engineering Handbook, Second Edition, Robert T. Ratay
7. Structural Renovation of Buildings: Methods, Details, and Design Examples, Second Edition - Alexander Newman, P.E., MBA, F.ASCE.

CODE	COURSE NAME	CATEGORY	L	T	P	CREDIT
222ECE009	PRESTRESSED CONCRETE DESIGN	PROGRAM ELECTIVE 4	3	0	0	3

**Permeable:** This course provides the basic principles of Prestressed concrete design of structures. Students are introduced to the engineering aspects of prestressed concrete design, principles, and losses in prestressed concrete. This course covers the basic principles, design of flexural, compression, and tension members as per IS standards. This course also includes design of composite members.

**Course Outcomes:** After the completion of the course the student will be able to

<b>CO 1</b>	Describe the basic aspects of prestressed concrete structures
<b>CO 2</b>	Compute the losses of prestressing
<b>CO 3</b>	Analyse and design a prestressed concrete structural members and sections subjected to axial load and flexure
<b>CO 4</b>	Analyse and design a prestressed concrete structural members subjected to shear and torsion
<b>CO 5</b>	Design prestressed concrete structural members.
<b>CO 6</b>	Estimate crack width and deflection in prestressed concrete members.

#### Mapping of course outcomes with program outcomes

	PO 1	PO 2	PO 3	PO 4	PO 5	PO 6	PO 7
<b>CO 1</b>	1		1				
<b>CO 2</b>	1		1				
<b>CO 3</b>	1		3	2			
<b>CO 4</b>	1	1	3	2			
<b>CO 5</b>	1	1	3	2			
<b>CO 6</b>	1	1	2				

(1- Weak, 2-Medium, 3- strong)

#### Assessment Pattern

Bloom's Category	End Semester Examination
Remember	15
Understand	20
Apply	25
Analyse	
Evaluate	

## Mark distribution

Total Marks	CIE	ESE	ESE Duration
100	40	60	2.5 hours

### Continuous Internal Evaluation Pattern:

Preparing a review article based on peer reviewed Original Publication (minimum 10 publications shall be referred) : 15 marks  
Course based task/Seminar/Data collection and interpretation: 15 marks  
Test Paper 1 No : 10 marks

Test paper shall include minimum 80% of the syllabus

### End Semester Examination Pattern:

The end semester examination will be conducted by the respective College. There will be two parts; Part A and Part B. Part A will contain 5 numerical/short answer questions with 1 question from each module, having 5 marks for each question (such questions shall be useful in the testing of knowledge, skills, comprehension, application, analysis, synthesis, evaluation and understanding of the students).

Students should answer all questions. Part B will contain 7 questions (such questions shall be useful in the testing of overall achievement and maturity of the students in a course, through long answer questions relating to theoretical/practical knowledge, derivations, problem solving and quantitative evaluation), with minimum one question from each module of which student should answer any five. Each question can carry 7 marks.

**Note:** The marks obtained for the ESE for an elective course shall not exceed 20% over the average ESE mark % for the core courses. ESE marks awarded to a student for each elective course shall be normalized accordingly. For example, if the average end semester mark % for a core course is 40, then the maximum eligible mark % for an elective course is  $40+20 = 60\%$ .

**QP CODE:**

**Name:**

**Reg. No.:**

**APJ ABDUL KALAM TECHNOLOGICAL UNIVERSITY SECOND SEMESTER  
M.TECH. DEGREE EXAMINATION, MONTH & YEAR**

**Course Code: 222ECE009**

**PRESTRESSED CONCRETE DESIGN**

Max. Marks: 60

Duration: 2.5Hours

*Use of relevant codes are permitted*

*Assume suitable data with justification*

*Limit the answers to the required points*

**PARTA**

***Answer All Questions***

***Each question carries 5marks***

1. Discuss the basic assumptions in analysis of prestressed Concrete.
2. Write notes on anchorage reinforcement.
3. List out the methods to achieve continuity in beams.
4. Mention the advantages of composite sections.
5. Mention the difference in the design of prestressed concrete slab from the prestressed concrete beam.

**PART-B**

6. A rectangular prestressed beam 150 mm x 300 mm, have an effective span of 10m. The cable with zero eccentricity at the supports and linearly varying to 50 mm at the centre, carries an effective prestressing force of 500kN. Find the magnitude of concentrated load Q located at the centre of the span if the load counteracts the bending effects of the prestressing force (neglecting self-weight of the beam).
7. The support section of prestressed concrete beam, 100mm x 250mm, is required to support an ultimate shear force of 60kN. The compressive prestress at the centroidal axis is 5N/mm<sup>2</sup>. The characteristic cube strength and characteristic strength of steel in stirrups are 40MPa and 250MPa respectively. Design suitable reinforcements at the section using the IS:1343 recommendations.
8. A continuous prestressed concrete beam ABC (AB=BC=10m) has an uniform rectangular section of 100mm x 300mm. The cable carrying an effective prestressing force of 360kN is parallel to the axis of the beam and located at 100mm from the soffit.
  - a. Determine the secondary and resultant moment at the central support

b. Locate the resultant line of thrust.

9. A composite T-girder of span 5m is made up of a pre-tensioned rib, 100mm wide by 200mm depth, with an in-situ cast slab, 400mm wide 40mm thick. The rib is prestressed by a straight cable having an eccentricity of 33.33mm and carrying initial force of, 150kN. The loss of prestress is 15%. Check the composite T-beam for the limit state of deflection if its supports an imposed load of 3.2kN/m for (i) unpropped (ii) propped. Assume modulus of elasticity of 35kN/mm<sup>2</sup> for both precast and in situ cast elements.
10. Design a prestressed concrete pipe of internal dia 900mm to withstand the internal pressure of 0.8Mpa. the max. Permissible compressive stress in concrete is 18 MPa and no tensile stress is to be permitted. Modular ratio between steel and concrete is 5.8. adopt 5mm diameter high tensile wires which can be stressed to 1100MPa.
11. Briefly explain the various steps involved in the design of continuous prestressed concrete beams.
12. Recall the design procedure for prestressed circular water tank.

\*\*\*\*\*

## Syllabus

### Module 1

Basic Concept of prestressing–Historical overview of prestressing–Advantages and disadvantages – Materials required – Systems and methods of prestressing–Analysis of sections – Stress concept – Strength concept – Load balancing concept – Effect of loading on the tensile stresses in tendons – Effect of tendon profile on deflections – Factors influencing deflections – Calculation of deflections – Short term and long-term deflections - Losses of prestress – Estimation of crack width.

### Module 2

Basic assumptions of flexural design – Permissible stresses in steel and concrete as per I.S.1343 Code – Different types of sections - Design of sections of Type I and Type II post-tensioned and pre tensioned beams – Check for flexural capacity based on I.S. 1343 Code – Influence of Layout of cables in post-tensioned beams – Location of wires in pre-tensioned beams – Design for shear based on I.S. 1343 Code.

### Module 3

Analysis and design of continuous beams, Methods of achieving continuity, Concept of linear transformations, concordant cable profile and gap cables, Analysis and design of cantilever beams

### Module 4

Composite Sections – Types – Advantages, Analysis of stresses for composite sections, applications, Composite beams Analysis and design of Flexural and shear strength, Partial prestressing - its advantages and applications.



**Module 5**

Role of prestressing in members subjected to Tensile forces and compressive forces  
 - Design of tension and compression members – Tanks, pipes and poles – Design of prestressed concrete slab.

**Course Plan**

<b>No</b>	<b>Topic</b>	<b>No. of Lectures</b>
<b>1</b>	<b>PRINCIPLES OF PRESTRESSING (8)</b>	
1.1	Basic Concept of prestressing, Brief History, Advantages	1
1.2	Types of Prestressing and System of Prestressing	1
1.3	Analysis of sections	1
1.4	Stress concept, Strength concept, Load balancing concept	2
1.5	Prestressing Devices , Need for High Strength materials	1
1.6	Estimation of deflection and crack width (Briefly)	1
1.7	Losses of Prestress	1
<b>2</b>	<b>DESIGN OF FLEXURAL MEMBERS (8)</b>	
2.1	Behaviour of flexural members	1
2.2	Design of sections as per code for pre-tensioned and post-tensioned rectangular beams- Various Codal provisions	1
2.3	Design for ultimate and serviceability limit states for flexure	2
2.4	Analysis and Design for shear and torsion.	2
2.5	Design of anchorage zone reinforcement (end block)	2
<b>3</b>	<b>DESIGN OF CONTINUOUS AND CANTILEVER BEAMS (8)</b>	
3.1	Analysis and design of continuous beams	2
3.2	Methods of achieving continuity	2
3.3	Concept of linear transformations, concordant cable profile and gap cables	2
3.4	Analysis and design of cantilever beams	2
<b>4</b>	<b>ANALYSIS &amp; DESIGN OF COMPOSITE MEMBERS (8)</b>	
4.1	Composite Sections – Types – Advantages	2
4.2	Analysis of stresses for composite sections, applications.	2
4.3	Composite beams Analysis and design of Flexural and shear strength	2
4.4	Partial prestressing - its advantages and applications.	2
<b>5</b>	<b>DESIGN OF TENSION AND COMPRESSION MEMBERS (8)</b>	
5.1	Design of concrete pipes - Circular tanks, poles –Prestressed concrete slabs	3
5.2	Design of compression members with and without flexure	3
5.3	Its application in the design piles, flag masts and similar structures.	2

**Reference Books**

1. Krishna Raju N., "Prestressed concrete", 5th Edition, Tata McGraw Hill Company, New Delhi, 2012
2. Pandit.G.S. and Gupta.S.P., "Prestressed Concrete", CBS Publishers and Distributors Pvt. Ltd, 2012
3. Rajagopalan.N, "Prestressed Concrete", Narosa Publishing House, 2002.
4. Dayaratnam.P., "Prestressed Concrete Structures", Oxford and IBH, 2013
5. Lin T.Y. and Ned.H.Burns, "Design of prestressed Concrete Structures", Third Edition, Wiley India Pvt. Ltd., New Delhi, 2013.
6. IS 1343:2012, Code of Practice for Prestressed Concrete, Bureau of Indian Standards, New Delhi, 2012
7. IS 3370- Part 3 (1967) (Reaffirmed – 2008) Indian standard Code of practice for concrete structures for the storage of liquids, Bureau of Indian Standards, New Delhi, 2008
8. IS 3370- Part 4 (2008) Indian standard Code of practice for concrete structures for the storage of liquid- Design tables, Bureau of Indian standards, New Delhi



APJ ABDUL KALAM  
TECHNOLOGICAL  
UNIVERSITY

---

# **SEMESTER II**

---

## **INTERDISCIPLINARY ELECTIVE**

---

Estd.



2014

CODE	COURSE NAME	CATEGORY	L	T	P	CREDIT
222ECE097	MECHANICS OF COMPOSITE MATERIALS	INTERDISCIPLINARY ELECTIVE	3	0	0	3

**Preamble:** Fibre reinforced plastic composite materials are finding wide range of applications in the field of aerospace structures, automobile engineering, offshore structures, maritime structures, ships and civil engineering structures presently due to its outstanding material capabilities such as High strength, low weight, high corrosion resistance, high fatigue strength and faster assembly. The everyday applications of composites in the commercial markets and hence the job opportunities in this field are drastically increasing nowadays. This course will equip the students with the specialist knowledge and skills required by the leading employers in aerospace, marine, automobile, construction and renewable energy industries to design and develop next generation environmental-friendly and structural-efficient advanced lightweight composite materials and components.

**Course Outcomes:** The COs shown are only indicative. For each course, there can be 4 to 6 COs.

After the completion of the Advanced Composite Structures course the student will be able to

<b>CO 1</b>	Identify the properties of fibre and matrix materials used in commercial composites, as well as some common manufacturing techniques.
<b>CO 2</b>	Explain linear elasticity with emphasis on the difference between layered composite materials and isotropic materials.
<b>CO 3</b>	Apply constitutive equations of composite materials and understand the mechanical behaviour at micro and macro levels.
<b>CO 4</b>	Predict the failure mode and strength of laminated composite structures.
<b>CO 5</b>	Apply the ideas developed in the analysis of composites towards using composites in various fields of engineering.

#### Mapping of course outcomes with program outcomes

	PO 1	PO 2	PO 3	PO 4	PO 5	PO 6	PO 7
<b>CO 1</b>			3	3	2		
<b>CO 2</b>			3	3	2		
<b>CO 3</b>			3	3	2		
<b>CO 4</b>			3	3	2		
<b>CO 5</b>			3	3	2		

**Assessment Pattern**

<b>Bloom's Category</b>	<b>End Semester Examination</b>
Remember	15
Understand	15
Apply	25
Analyse	5
Evaluate	-
Create	-

**Mark distribution**

<b>Total Marks</b>	<b>CIE</b>	<b>ESE</b>	<b>ESE Duration</b>
100	40	60	2.5 hours

**Continuous Internal Evaluation Pattern:**

Preparing a review article based on peer reviewed original publications (minimum 10 publications shall be referred): 15 marks

Course based task/Seminar/Data collection and interpretation: 15 marks

Test paper, 1 no.: 10 marks

Test paper shall include minimum 70% of the syllabus.

**End Semester Examination Pattern:**

The end semester examination will be conducted by the respective College. There will be two parts; Part A and Part B. Part A will contain 5 numerical/short answer questions with 1 question from each module, having 5 marks for each question (such questions shall be useful in the testing of knowledge, skills, comprehension, application, analysis, synthesis, evaluation and understanding of the students). Students should answer all questions. Part B will contain 7 questions (such questions shall be useful in the testing of overall achievement and maturity of the students in a course, through long answer questions relating to theoretical/practical knowledge, derivations, problem solving and quantitative evaluation), with minimum one question from each module of which student should answer any five. Each question can carry 7 marks.

**Note:** The marks obtained for the ESE for an elective course shall not exceed 20% over the average ESE mark % for the core courses. ESE marks awarded to a student for each elective course shall be normalized accordingly. For example, if the

average end semester mark % for a core course is 40, then the maximum eligible mark % for an elective course is  $40 + 20 = 60$  %.

### Model Question paper

#### PART A

Answer **all** questions.

All Questions carry **equal** marks

1. How is the mechanical advantage of a composite measured?
2. Write the number of independent elastic constants for three dimensional anisotropic, orthotropic, transversely isotropic and isotropic materials.
3. What is Classical Lamination Theory? Explain its significance in composite analysis.
4. The weight fraction of glass in a glass epoxy composite is 0.8. If the specific gravity of glass and epoxy are 2.5 and 1.2 respectively, find (i) fibre and matrix volume fractions (ii) density of composite?
5. Explain briefly the progressive failure analysis in a composite laminate.

#### PART B

Answer any **FIVE** questions only

6. Briefly explain the Hooke's law for Anisotropic materials. Derive the stress-strain relation for a material with three planes of reflection and one  $90^\circ$  rotation symmetry
7. (a) Explain any two methods of manufacturing of composite in detail.  
(b) Derive the relations connecting the engineering constants and the elements of stiffness and compliance matrices for a specially orthotropic lamina.
8. (a) Calculate the longitudinal modulus and tensile strength of a unidirectional composite containing 60% by volume of carbon fibres ( $E_{lf} = 294$  GPa and  $\sigma_{lfu} = 5.6$  Gpa) in a toughened epoxy matrix ( $E_m = 3.6$  GPa and  $\sigma_{mu} = 105$  Gpa). Compare these values with the experimentally determined values of  $E_1 = 162$  GPa and  $\sigma_{1u} = 2.94$  GPa. What fraction of load is carried by fibres in the composite?  
(b) Explain how to calculate the effective moduli of a composite lamina in terms of its constituent properties.
9. (a) Explain the free edge effects and interlaminar stresses in composite laminates  
(b) Explain how to determine the laminae stresses and strains from the analysis of a laminate?
10. Calculate the A, B, D matrices for a  $[0/90^\circ]$  laminate each layer of which is of 0.125 mm thickness. The lamina properties are given by  $E_1 = 140$  GPa,  $E_2 = 10$  GPa,  $G_{12} = 5$  GPa,  $\nu_{12} = 0.3$
11. (a) Explain the effect of interlaminar stresses in composite laminate in detail  
(b) Explain the importance of the sign of shear stress on strength of composites.

12. Find the maximum value of  $S > 0$  if a stress of  $\sigma_x = 2S$ ,  $\sigma_y = -3S$ , and  $\tau_{xy} = 4S$  is applied to a  $60^\circ$  Graphite/epoxy Lamina. Use Tsai-Hill Failure theory.

Given  $(\sigma_1^t)_{ult} = 1500 \text{ MPa}$ ,  $(\sigma_1^c)_{ult} = 1500 \text{ MPa}$ ,  $(\sigma_2^t)_{ult} = 40 \text{ MPa}$ ,  $(\sigma_2^c)_{ult} = 246 \text{ MPa}$ ,  
 $(\tau_{21})_{ult} = 68 \text{ MPa}$

### Syllabus and Course Plan

No	Topic	No. of Lectures
1	<b>Introduction to Composite Materials (6)</b>	
1.1	Definition of composites, Objectives, constituents and Classification of composites.	2
1.2	Basic terminology used in fibre reinforced composite materials- Lamina, Laminates, General Characteristics of reinforcement and classifications, Characteristics of matrix- Polymer matrix, Thermoplastics and thermosetting resins, Glass transition temperature, Prepregs	2
1.3	Structural applications of Composite Materials	1
1.4	Processing of Composites	1
2	<b>Macro mechanical behaviour of a composite lamina (9)</b>	
2.1	Review of Basic Equations of Mechanics and Materials, Hooke's law for different types of materials- Anisotropic, orthotropic, isotropic, monoclinic and Transversely isotropic materials.	2
2.2	Stress-Strain relations for a Two dimensional unidirectional and orthotropic lamina, lamina of arbitrary orientation, Transformations of stress and strain	3
2.3	Relationship of Compliance and stiffness matrix to elastic constants of a lamina	1
2.4	Strength and Failure theories of Continuous Fibre-reinforced orthotropic Lamina- Failure envelopes, Maximum stress/strain criteria, Tsai-Hill and Tsai-Wu criterion.	2
2.5	Hygrothermal stresses and strains in a lamina –unidirectional and angle lamina	1
3	<b>Micromechanical Behaviour of a Lamina (6)</b>	
3.1	Volume and Mass fractions, density and void content	1
3.2	Effective Moduli of a continuous fibre-reinforced lamina – Models based on mechanics of materials, theory of elasticity and experimental methods, Mechanics of materials approach to strength, Numerical Examples	2
3.3	Ultimate Strengths of unidirectional Lamina- longitudinal and transverse tensile and compressive strengths	2
3.4	Coefficients of moisture and thermal expansion	1
4	<b>Macro mechanical behaviour of Laminates (10)</b>	

4.1	Classical Lamination Theory-Laminae Stress-strain behaviour, In-plane forces, stress-strain variation in a laminate, resultant laminate stresses and strains,	3
4.2	Special cases of laminate stiffnesses-symmetric and antisymmetric laminates, cross ply and angle ply laminates, quasi-isotropic laminates	3
4.3	Inplane and flexural modulus of a laminate	1
4.4	Effects of stacking sequence-Laminate code	1
4.5	Free-Edge Interlaminar Effects, Hygro-thermal effects and warpage in a laminate	2
5	<b>Strength and Design of Laminates (9)</b>	
5.1	Determination of laminae stresses and strains, numerical examples	2
5.2	Laminate strength analysis procedure, Failure envelopes	3
5.3	Analysis of laminates after initial failures, Progressive failure Analysis. Numerical Examples	2
5.4	Composite mechanical design issues-Long-term environmental effects, impact resistance, fracture resistance, fatigue resistance	2

### Text Books

1. Jones M. Roberts, Mechanics of Composite Materials, Taylor and Francis, 1998
2. Reddy, J.N , Mechanics of Laminated Composite Plates: Theory and Analysis, CRC Press, 2003

### Reference Books

1. Calcote, L. R., Analysis of Laminated Composite structures, Van Nostrand, 1969
2. Vinson, J. R. and Chou P, C., Composite materials and their use in Structures, Applied Science Publishers, Ltd. London, 1975
3. Agarwal, B.D. and Broutman, L. J., Analysis and performance of Fibre composites. 3<sup>rd</sup>Edn.



CODE	COURSE NAME	CATEGORY	L	T	P	CREDIT
222ECE098	PROJECT EVALUATION AND MANAGEMENT	INTERDISCIPLINARY ELECTIVE	3	0	0	3

**Preamble:** Objective of the course is to enable the students to understand the management aspects of project idea formulations, feasibility studies and report preparation, costing of project, project appraisal and project funding.

**Course Outcomes:** The COs shown are only indicative. For each course, there can be 4 to 6 COs.

After the completion of the course the student will be able to

<b>CO 1</b>	To develop project ideas
<b>CO 2</b>	To do the feasibility analysis of projects
<b>CO 3</b>	To plan and arrive at Project Costs
<b>CO 4</b>	To carry out project appraisals
<b>CO 5</b>	To identify the various funding sources and select the apt source

#### Mapping of course outcomes with program outcomes

	PO 1	PO 2	PO 3	PO 4	PO 5	PO 6	PO 7
<b>CO 1</b>	2		3	2		2	
<b>CO 2</b>	2		2				
<b>CO 3</b>	3	2		3			
<b>CO 4</b>	2		2	2	2		
<b>CO 5</b>	2		2	1			

#### Assessment Pattern

Bloom's Category	End Semester Examination
Understand	20
Apply	10
Analyse	10
Evaluate	20
Create	

#### Mark distribution

Total Marks	CIE	ESE	ESE Duration
100	40	60	2.5 hours

**Continuous Internal Evaluation Pattern:**

Preparing a review article based on peer reviewed

Original publications (minimum 10 publications shall be referred) : 15 marks

Course based task/Seminar/Data collection and interpretation : 15 marks

Test paper, 1 no. : 10 marks

Test paper shall include minimum 80% of the syllabus.

**End Semester Examination Pattern:**

The end semester examination will be conducted by the respective College. There will be two parts; Part A and Part B. Part A will contain 5 numerical/short answer questions with 1 question from each module, having 5 marks for each question (such questions shall be useful in the testing of knowledge, skills, comprehension, application, analysis, synthesis, evaluation and understanding of the students). Students should answer all questions. Part B will contain 7 questions (such questions shall be useful in the testing of overall achievement and maturity of the students in a course, through long answer questions relating to theoretical/practical knowledge, derivations, problem solving and quantitative evaluation), with minimum one question from each module of which student should answer any five. Each question can carry 7 marks. Note: The marks obtained for the ESE for an elective course shall not exceed 20% over the average ESE mark % for the core courses. ESE marks awarded to a student for each elective course shall be normalized accordingly. For example if the average end semester mark % for a core course is 40, then the maximum eligible mark % for an elective course is  $40+20 = 60$  %.

Estd.



2014

**Model Question Paper****Model Question paper**

Course Code & Name:

**Project Evaluation and Management**

Max. Marks: 60

Duration: 2.5 hours

**PART A**

**(Answer all Questions: Each question carries 5 marks)**

1. Discuss the need for project idea generation ?
2. Why feasibility studies are essential?
3. What do you understand by Present value of a single amount?
4. Explain the international practice of Project Appraisal.
5. Discuss the means of Project Financing.

**PART B**

**(Answer any *five* questions: Each carries 7 marks)**

6. Describe the various steps involved in Project Identification.
7. How will you assess the technical feasibility of a project?
8. Explain cash flow and what are the benefits of cash flow statement..
9. Discuss the various methods of Risk Analysis
10. Bluebell Enterprises had invested Rs.2,00,00,000 for the purpose of replacing some of its machinery components. This renovation is expected to result in incremental benefits of Rs.5000000 in 1<sup>st</sup> year, Rs.3000000 in 2<sup>nd</sup> year and Rs. 4000000 in 3<sup>rd</sup> year. Calculate the benefit-cost ratio of the replacement project if the applicable discounting rate is 5%..
11. Discuss the role of various institutions for project financing
12. Discuss the Private Sector Participation on Infrastructure Projects in India

**Syllabus and Course Plan** (For 3 credit courses, the content can be for 40 hrs and for 2 credit courses, the content can be for 26 hrs. The audit course in third semester can have content for 30 hours).

No	Topic	No. of Lectures
1	Project formulation	
1.1	Concepts of Project, Capital Investments	2
1.2	Purpose and need for Project Identification	2
1.3	Methodology for Project Identification	2
1.4	Steps in Project Identification	2
2	Project Feasibility	
2.1	Introduction to feasibility Studies, need for feasibility studies	2
2.2	Components of Feasibility Analysis - Market, Technical, Financial, Economic	4
2.3	Feasibility Reports and approvals	2
3	Project Costing	
3.1	Time Value of Money - Future value of single amount, Present value of single amount, Future value of an annuity, Present value of an annuity, Simple interest-Compound interest	3
3.2	Project Cash Flows	3
3.3	Cost of capital	2
4	Project Appraisal	
4.1	Investment Criteria- Discounting criteria-Net present value (NPV), Benefit cost ratio(BCR), internal rate of return(IRR)- Non-Discounting criteria - Pay Back Period, Accounting rate of return(ARR	4
4.2	Indian and International Practice of Appraisal	2
4.3	Methods of Analysis of Risk	2
5	Project Financing	
5.1	Project Financing – Means of Finance	2
5.2	Financial Institutions, schemes	3
5.3	Private sector participation in Infrastructure Development Projects - BOT, BOLT, BOOT	2
5.4	Technology Transfer and Foreign Collaboration	1

### Reference Books

- 1 Project Planning Analysis selection financing Implementation and Review- Tata Mc Graw Hill Publication, 7th edition 2010, Prasana Chandra
- 2 United Nations Industrial Development Organization (UNIDO) Manual for the preparation of Industrial Feasibility Studies, (IDSI Reproduction), Bombay, 2007.

- 3 A Systems Approach to Planning, Scheduling, and Controlling Project Management Harold Kerzner (2013), Wiley India, New Delhi
- 4 Project planning scheduling & control, James P.Lewis, Meo Publishing Company 2001
- 5 Project planning analysis selection implementation & review Prasanna Chandra, ISBN0-07-462049-5 2002.

APJ ABDUL KALAM  
TECHNOLOGICAL  
UNIVERSITY

KTU

Estd.



2014